



Doc. version :	0.5
Total pages :	56
Date :	2007/10/18

Product Specification

2.36" COLOR TFT-LCD MODULE

MODEL NAME: A024CN02 VH/01

< ◆ > Preliminary Specification

< > Final Specification

Note: The content of this specification is subject to change.

© 2006 AU Optronics
All Rights Reserved,
Do Not Copy.



Contents:

A. Physical specifications..... 4

B. Electrical specifications 5

 2. Pin assignment5

 3. Absolute maximum ratings6

 4. Electrical characteristics7

 a. Typical operating conditions (GND=AVss=0V).....7

 b. Current characteristics (GND=AVss=0V)7

 c. LED driving conditions.....8

 4. AC Timing9

 a. Digital Signal AC Characteristic9

 b. UPS051 Timing conditions 10

 c. UPS052 Timing conditions 13

 d. CCIR656 Timing conditions..... 16

 e. YUV Timing 18

 5. Charge Pump Structure.....22

 6. Reference Circuit.....23

 7. Serial Interface & Register Table29

 a. Serial Interface format29

 b. The configuration of serial data at SDA terminal is at below.....29

 c. Register parameters30

 d. Detail Register Description.....31

C. Optical specification (Note 1,Note 2, Note 3) 38

D. Reliability test items: 40

E. Packing form 41

F. Outline dimension..... 42

G. Application Notes..... 43

 1. Stand-by timing.....43

 2. Power on sequence.....44

 3. Power off sequence - 145

 4. Recommended power on/off serial command settings.....46

 4.1. Recommend UPS051 (9.7 MHz) power on/off setting47

 4.2. Recommend UPS052 320RGB mode (24.54 MHz) power on/off setting48

 4.3. Recommend UPS052 360RGB mode (27MHz) power on/off setting49

 4.4. Recommend YUV mode A 640Y 320CrCb (24.54 MHz) power on/off setting50

 4.5. Recommend YUV mode A 720Y 360CrCb (27 MHz) power on/off setting51



- 4.6. Recommend YUV mode B 640Y 320CrCb (24.54 MHz) power on/off setting.....52
- 4.7. Recommend YUV mode B 720Y 320CrCb (27 MHz) power on/off setting.....53
- 4.8. Recommend CCIR656 mode (27 MHz) power on/off setting.....54
- 5 The Difference between This model and Previous models (A024CN02 V0 ~ V8, VA)55**
 - a. VCOM DC setting.....55
 - b. VCOM Couple capacitor.....55
 - c. PWM RC Parameters.....56
 - d. ESD Protection.....56



A. Physical specifications

NO.	Item	Specification	Remark
1	Display resolution (dot)	480(W)×234(H)	
2	Active area (mm)	48.0 (W) × 35.685 (H)	
3	Screen size (inch)	2.36 (Diagonal)	
4	Dot pitch (mm)	0.10 (W) × 0.1525 (H)	
5	Color configuration	R. G. B. delta	
6	Overall dimension (mm)	55.2 (W) × 47.55 (H) × 2.9 (D)	Note 1
7	Weight (g)	TBD	
8	Panel surface treatment	Hard coating	

B. Electrical specifications

2. Pin assignment

Pin no	Symbol	I/O	Description	Remark
1	VCOM	I	Common electrode driving voltage	
2	VGLC	C	Pins to connect capacitance for negative high power supply	
3	VGL	C	Negative low power supply for gate driver output: -12.5V	
4	C4P	C	Pins to connect capacitance for power circuitry	
5	C4M	C	Pins to connect capacitance for power circuitry	
6	VGH	C	Positive power supply for gate driver output: +12.5V	
7	FRP	O	Frame polarity output for VCOM	
8	VCAC	C	Define the amplitude of the VCOM swing	
9	Vint3	C	Intermediate voltage for charge Pump	
10	C3P	C	Pins to connect capacitance for power circuitry	
11	C3M	C	Pins to connect capacitance for power circuitry	
12	Vint2	C	Intermediate voltage for charge Pump	
13	C2P	C	Pins to connect capacitance for power circuitry	
14	C2M	C	Pins to connect capacitance for power circuitry	
15	Vint1	C	Intermediate voltage for charge Pump	
16	C1P	C	Pins to connect capacitance for power circuitry	
17	C1M	C	Pins to connect capacitance for power circuitry	
18	PGND	P	Charge Pump Power GND	
19	PVDD	P	Charge Pump Power VDD	
20	DRV	O	Gate signal for the power transistor of the boost converter	
21	LED Anode	P	For Led Anode voltage	
22	GND	P	Digital GND	
23	FB	P/I	Led Cathode and main boost regulator feedback input	
24	AVDD	P	Analog power supply	
25	GND	P	Digital GND	
26	VCC	P	Digital power supply	
27	CS	I	Serial communication chip select	
28	SDA	I/O	Serial communication data input/output	
29	SCL	I	Serial communication clock input	
30	HSYNC	I	Horizontal sync input	
31	VSYNC	I	Vertical sync input	
32	DCLK	I	Clock Input:	
33	D7	I	Data Input: MSB	

34	D6	I	Data Input:	
35	D5	I	Data Input:	
36	D4	I	Data Input:	
37	D3	I	Data Input:	
38	D2	I	Data Input:	
39	D1	I	Data Input:	
40	D0	I	Data Input: LSB	

I: Input; O: Output. P: Power. I/O input/output C: Capacitor pin. P/I: power / input.

Note: Definition of scanning direction. Refer to figure as below

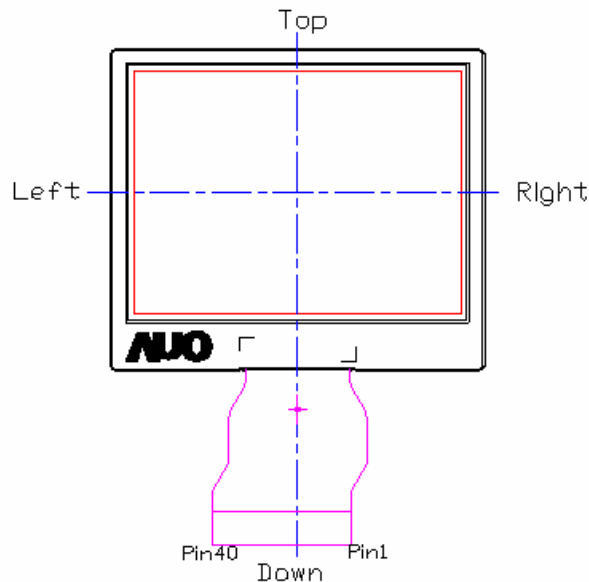

3. Absolute maximum ratings

Item	Symbol	Condition	Min.	Max.	Unit	Remark
Power voltage	V_{CC}	GND=0	-0.5	7.0	V	Digital Power Supply
	AV_{DD}	$AV_{SS}=0$	-0.5	7.0	V	Analog Power Supply
	PV_{DD}	$PV_{SS}=0$	-0.5	7.0	V	Charge Pump Power Supply
Input signal voltage	Data	-	-0.3	3.6	V	
Input signal voltage	VCOM		-2.9	5.2	V	VCOM DC Voltage
Operating temperature	Topa	-	0	60	°C	Ambient temperature
Storage temperature	Tstg	-	-25	70	°C	Ambient temperature

4. Electrical characteristics

a. Typical operating conditions (GND=AVss=0V)

Item		Symbol	Min.	Typ.	Max.	Unit	Remark
Power Voltage		V_{CC}	2.7	3.3	3.6	V	Digital Power Supply
		AV_{DD}	3.0	3.3	3.6	V	Analog Power Supply
		PV_{DD}	3.0	3.3	3.6	V	Charge Pump Power Supply
Output Signal Voltage	H Level	V_{OH}	$V_{CC}-0.4$	-	V_{CC}	V	
	L Level	V_{OL}	GND	-	$GND+0.4$	V	
Input Signal Voltage	H Level	V_{IH}	$0.7 \times V_{CC}$	-	V_{CC}	V	
	L Level	V_{IL}	GND	-	$0.3V_{CC}$	V	
VCOM Voltage		V_{CAC}	5.4	5.8	6.4	V	V
		V_{CDC}	0.3	0.5	0.7	V	V
DRV output voltage		V_{DRV}	0	-	$-V_{CC}$	v	V
Analog stand by current		I_{st}	-	-	100	μA	DCLK is stopped

Note 1: A build-in power on reset circuit for PV_{DD} and V_{CC} is provided within the integrated LCD driver IC. The LCD module is in power save mode in default, and standby releasing is required after V_{CC} power on through serial control. Pleaser refer to the register STB setting for detail.

b. Current characteristics (GND=AVss=0V)

Parameter	Symbol	Condition	Min.	Typ.	Max.	Unit	Remark
Input Current for V_{CC}	I_{VCC} (Pin 26)	$V_{CC}=3.3V$	--	2	4	mA	$F_{DCLK}=24.54MHz$ (UPS052) Other registers are default setting
Input Current for AV_{DD}	I_{AVDD} (Pin 25)	$AV_{DD}=3.3V$	--	2.5	3	mA	
Input Current for PV_{DD}	I_{PVDD} (Pin 19)	$PV_{DD}=3.3V$	--	8	10	mA	
Output current	H Level	IOH	-	400	-	μA	
	L Level	IOL	-	-400	-	μA	
Analog stand by current	I_{AST}	$AV_{DD}=3.3V$	-	50	100	μA	DCLK is stopped
Digital stand by current	I_{DST}	$V_{CC}=3.3V$	-	--	100	μA	
DRV output current	I_{DRV}	$V_{CC} = 3.0V$ $DRV = 0.7V$	-	-	10	mA	



c. LED driving conditions

Parameter	Symbol	Min.	Typ.	Max.	Unit	Remark
LED current	I_L		25	28	mA	
LED voltage	V_L	-	3.8	4.4	V	Note1

Note 1 : Typical LED voltage : 3.2V/pcs,FB=0.6V, LED voltage: $V_L = 3.2+0.6=3.8V$. Refer to application circuit .

4. AC Timing

a. Digital Signal AC Characteristic

Parameter	Symbol	Min.	Typ.	Max.	Unit.
DCLK duty cycle	Tcwh/Tcwl	40	50	60	%Tcph
Data set-up time	Tdsu	12	-	-	ns
Data hold time	Tdhd	12	-	-	ns

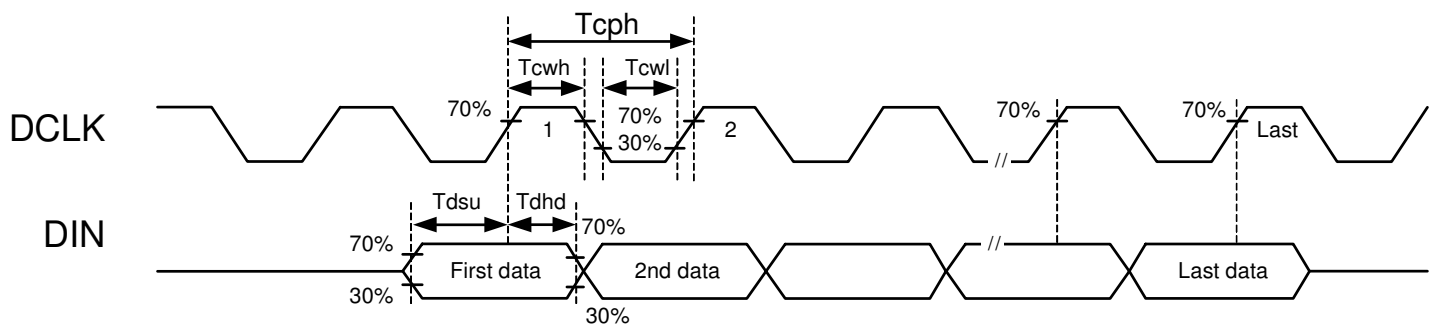

b. UPS051 Timing conditions

Parameter		Symbol	Min.	Typ.	Max.	Unit.	Remark	
DCLK Frequency		$1/t_{DCLK}$	8	9.7	12	MHz		
HSYNC	Period	t_H	580	616	649	DCLK	Note 1	
	Display period	t_{hdisp}	480			DCLK		
	Back porch	t_{hbp}	84	100	115	DCLK		
	Front porch	t_{hfp}	0	36	-	DCLK		
	Pulse width	t_{hsw}	1	20	50	DCLK		
VSYNC	Period	Odd	Note 4	262.5	Note 4	t_H	Note 2, 3, 5, 6	
		Even						
	Display period	Odd	t_{vdisp}	234				t_H
		Even						
	Back porch	Odd	t_{vbp}	11	18	24		t_H
		Even		10.5	17.5	23.5		
	Front porch	Odd	t_{vfp}	0	4.5	-		t_H
		Even		0	5	-		
	Pulse width	Odd	t_{vsw}	1	-	-		DCLK
		Even						
Data set-up time		t_{ds}	12			ns		
Data hold time		t_{dh}	12			ns		

Note 1: UPS051 Horizontal back porch time (t_{hbp}) is adjustable by setting register DDL; requirement of minimum back porch time and minimum front porch time must be satisfied.

Note 2: UPS051 Vertical back porch time (t_{vbp}) is adjustable by setting register HDL; requirement of minimum back porch time and minimum front porch time must be satisfied.

Note 3: Both interlace and non-interlace mode can be accepted.

Note 4: The min and max value of VSYNC period is related to Hsync period and Vs back porch.

Note 5: This chip support both interlace & non-interlace mode.

Note 6: Please keep frame over 50 Hz to get the better display quality.

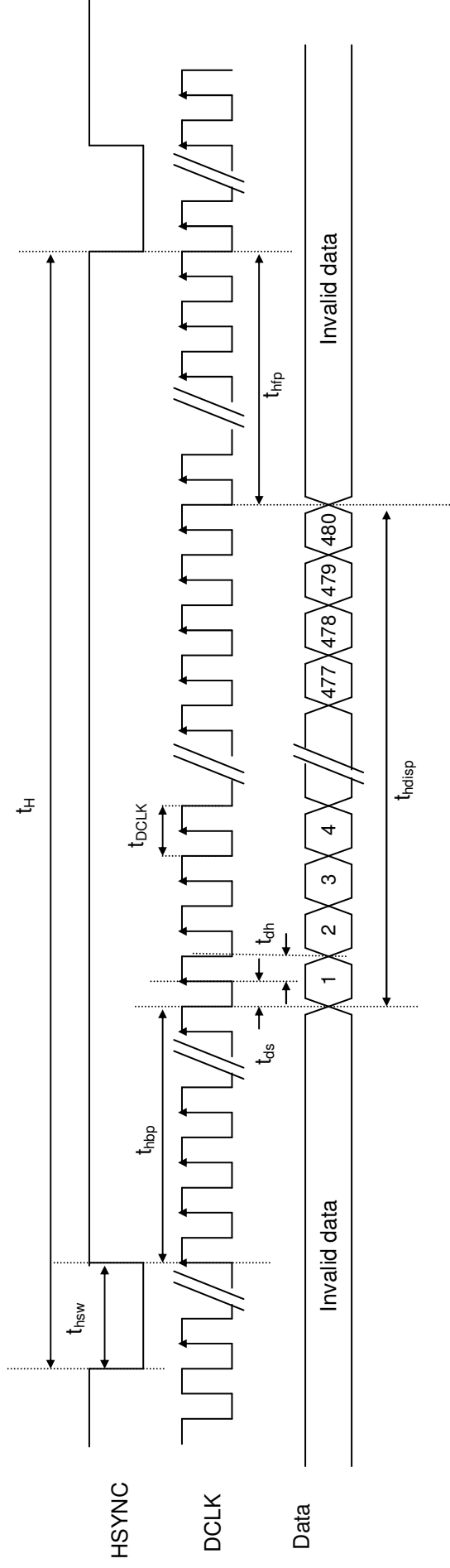

UPS051 Input Horizontal Signal

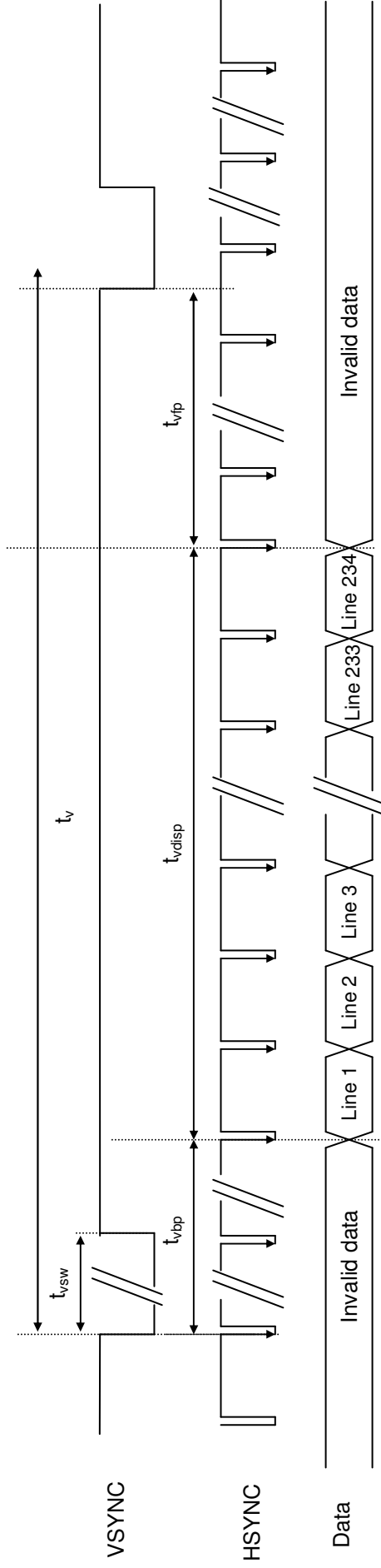

Odd Field

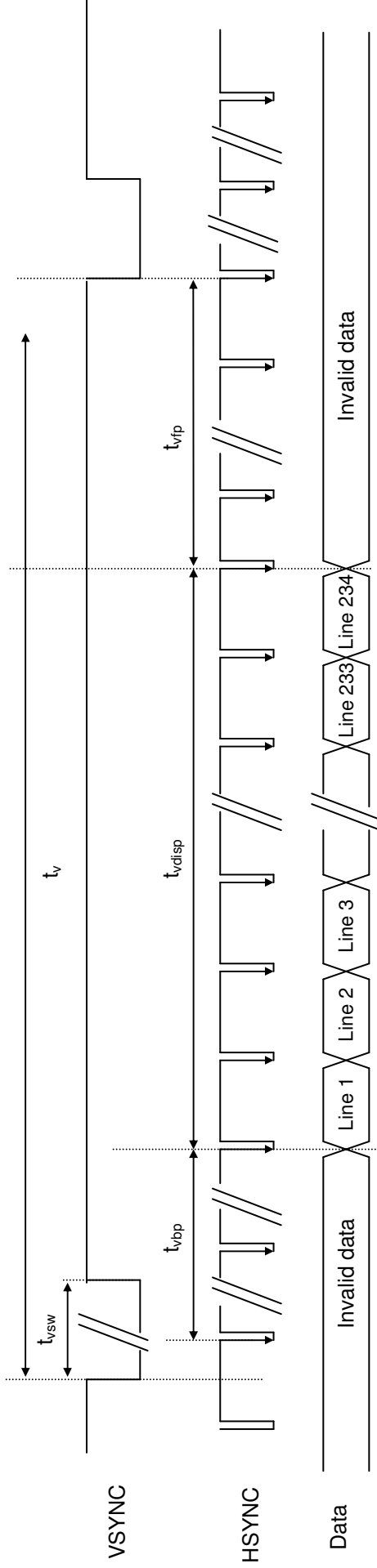

Even Field UPS051 Input Vertical Signal

c. UPS052 Timing conditions

c - 1. UPS052 (320 mode 24.545MHz) timing specifications

Parameter		Symbol	Min.	Typ.	Max.	Unit.	Remark	
DCLK Frequency		$1/t_{DCLK}$	16	24.55	27	MHz		
HSYNC	Period	t_H	1472	1560	1644	DCLK		
	Display period	t_{hdisp}	1280			DCLK		
	Back porch	t_{hbp}	220	252	283	DCLK		
	Front porch	t_{hfp}	0	-	-	DCLK		
	Pulse width	t_{hsw}	1	-	-	DCLK		
VSYNC	Period	Odd	Note 1	262.5	Note 1	t_H	Note 2, 3	
		Even						
	Display period	Odd	t_{vdisp}	240				t_H
		Even						
	Back porch	Odd	t_{vbp}	11	18	24		t_H
		Even		10.5	17.5	23.5		
	Front porch	Odd	t_{vfp}	0	4.5	-		t_H
		Even		0	5	-		
	Pulse width	Odd	t_{vsw}	1	-	-		DCLK
		Even						

Note 1: The min and max value of VSYNC period is related to Hsync period and Vs back porch.

Note 2: This chip support both interlace & non-interlace mode.

Note 3: Please keep frame over 50 Hz to get the better display quality.

c - 2. UPS052 (360 mode 27MHz) timing specifications

Parameter		Symbol	Min.	Typ.	Max.	Unit.	Remark	
DCLK Frequency		$1/t_{DCLK}$	16	27	27	MHz		
HSYNC	Period	t_H	1620	1716	1809	DCLK		
	Display period	t_{hdisp}	1440			DCLK		
	Back porch	t_{hbp}	220	252	283	DCLK		
	Front porch	t_{hfp}	0	-	-	DCLK		
	Pulse width	t_{hsw}	1	-	-	DCLK		
VSYNC	Period	Odd	Note 1	262.5	Note 1	t_H	Note 2, 3	
		Even						
	Display period	Odd	t_{vdisp}	240				t_H
		Even						
	Back porch	Odd	t_{vbp}	11	18	24		t_H
		Even		10.5	17.5	23.5		
	Front porch	Odd	t_{vfp}	0	4.5	-		t_H
		Even		0	-	-		
	Pulse width	Odd	t_{vsw}	1	-	-		DCLK
		Even						

Note 1: The min and max value of VSYNC period is related to Hsync period and Vs back porch.

Note 2: This chip support both interlace & non-interlace mode.

Note 3: Please keep frame over 50 Hz to get the better display quality.

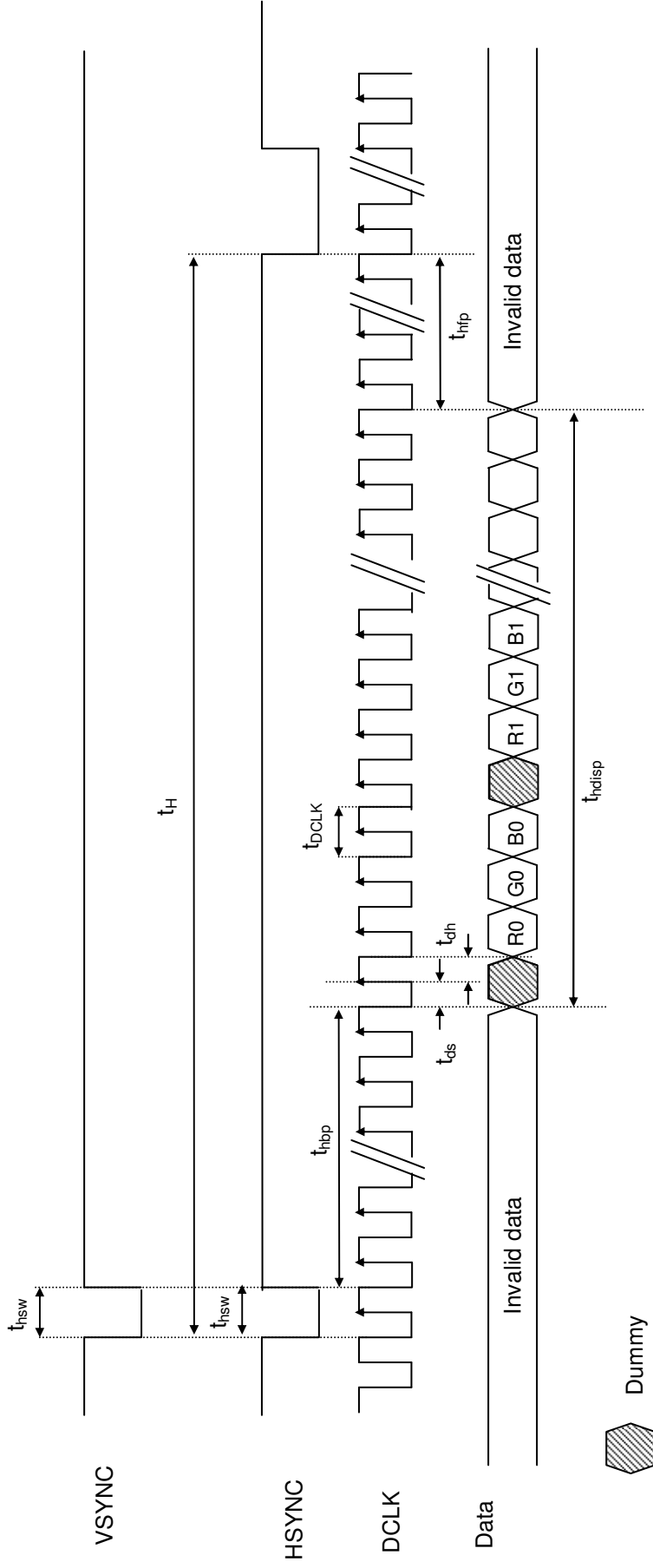

UPS052 Input Horizontal Signal

Note: Please send 00h as blanking data.

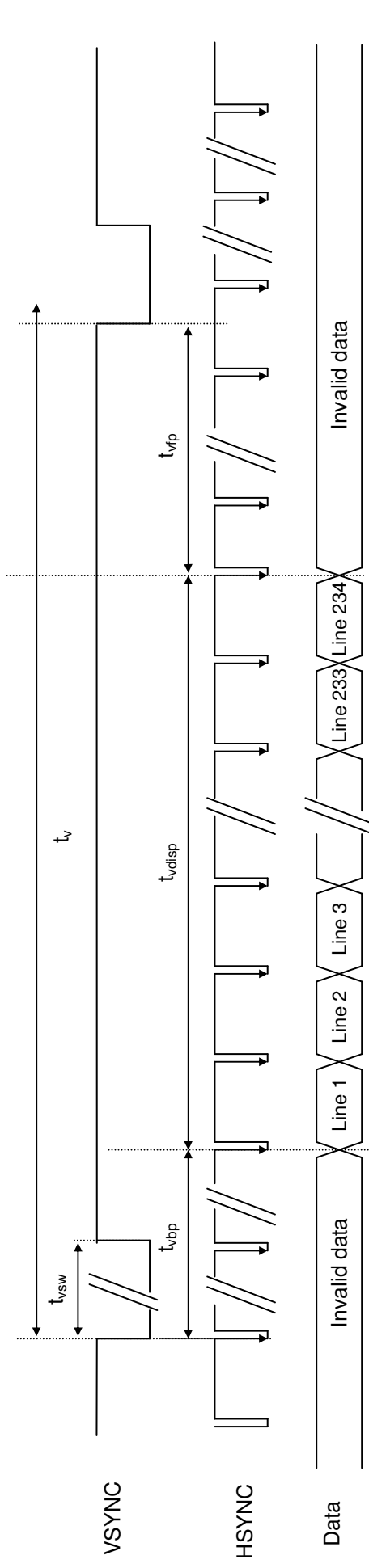

Odd Field

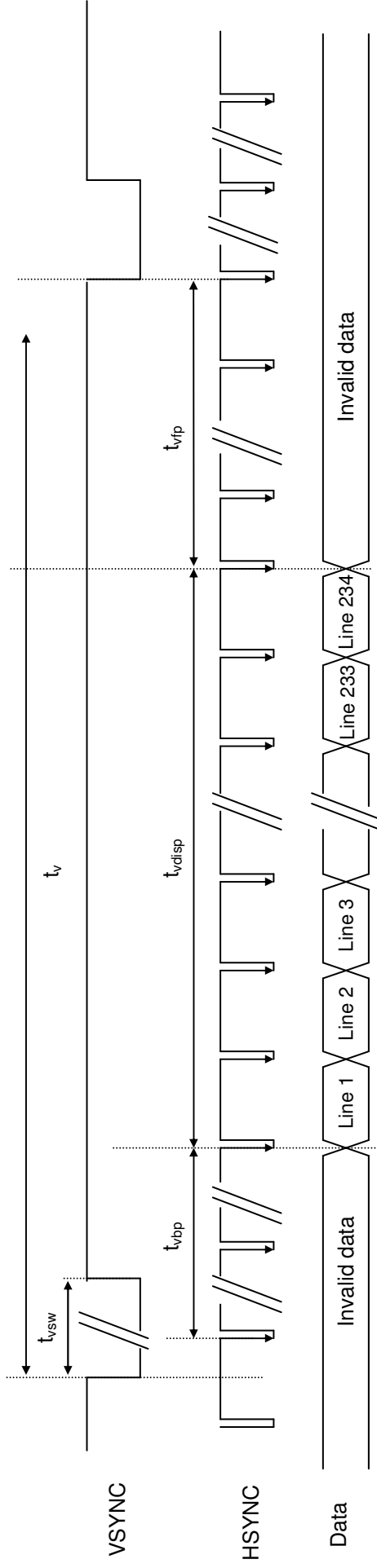

Even Field

UPS052 Input Vertical Signal

d. CCIR656 Timing conditions

d - 1. CCIR656 timing specifications

Parameter		Symbol	Min.	Typ.	Max.	Unit.	Remark	
DCLK Frequency		$1/t_{DCLK}$	16	27	27	MHz		
HSYNC	Period	t_H	1620	1716	1809	DCLK		
	Display period	t_{hdisp}	1440			DCLK		
	Back porch	t_{hbp}	241	273	304	DCLK		
	Front porch	t_{hfp}	4	4	4	DCLK		
	Pulse width	t_{hsw}	1	-	-	DCLK		
VSYNC	Period	Odd	t_V	Note 1	262.5	Note 1	t_H	Note 2
		Even						
	Display period	Odd	t_{vdisp}	240			t_H	
		Even						
	Back porch	Odd	t_{vbp}	11	18	24	t_H	
		Even		10.5	17.5	23.5		
	Front porch	Odd	t_{vfp}	0	4.5	-	t_H	
		Even		0	5	-		
	Pulse width	Odd	t_{vsw}	1	-	-	DCLK	
		Even						

Note 1: The min and max value of VSYNC period is related to Hsync period and Vs back porch.

Note 2: Please keep frame over 50 Hz to get the better display quality.

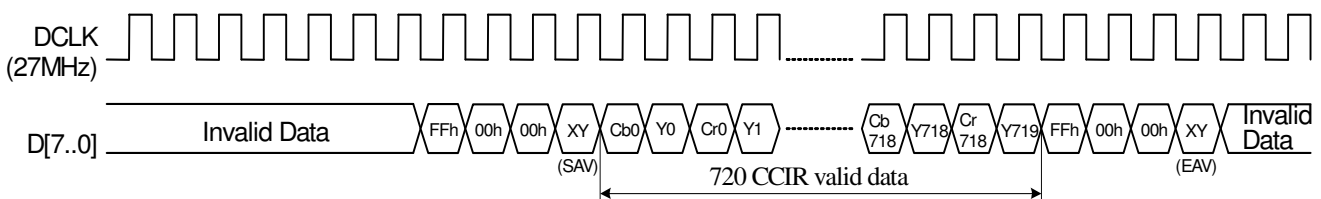

CCIR656 Data input format

d- 2. CCIR656 decoding

FF 00 00 XY signals are involved with HSYNC, VSYNC and Field

XY encode following bits:

F=field select

V=indicate vertical blanking

H=1 if EAV else 0 for SAV

P3-P0=protection bits

$P3 = V \oplus H$ $P2 = F \oplus H$ $P1 = F \oplus V$ $P0 = F \oplus V \oplus H$

\oplus represents the exclusive-OR function.

Control is provided through “End of Video” (EAV) and “Start of Video” (SAV) timing references.

Horizontal blanking section consists of repeating pattern 80 10 80 10

XY							
D7(MSB)	D6	D5	D4	D3	D2	D1	D0(LSB)
1	F	V	H	P3	P2	P1	P0

d- 3. CCIR656 to RGB conversion

$$R = 1.164(Y-16) + 1.596(Cr-128)$$

$$G = 1.164(Y-16) - 0.813(Cr-128) - 0.392(Cb-128)$$

$$B = 1.164(Y-16) + 2.017(Cb-128)$$

Where Y: 0~255 Cr: 0~255 Cb: 0~255

d- 4. CCIR656 Vertical Timing Format (NTSC)

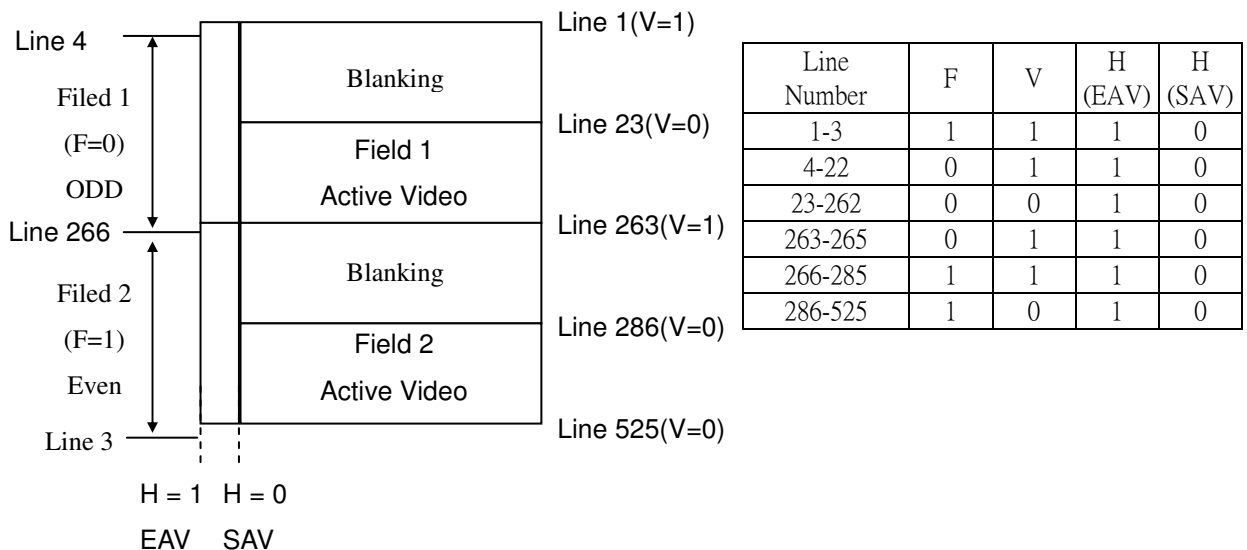

	F	H	V
1	Even Field	EAV	Blanking
0	Odd Field	SAV	Active Video

e. YUV Timing

e - 1. YUV 640 timing specifications

Parameter		Symbol	Min.	Typ.	Max.	Unit.	Remark	
DCLK Frequency		$1/t_{DCLK}$	16	24.545	27	MHz		
HSYNC	Period	t_H	1472	1560	1644	DCLK		
	Display period	t_{Hdisp}	1280			DCLK		
	Back porch	t_{Hbp}	220	252	283	DCLK		
	Front porch	t_{Hfp}	0	-	-	DCLK		
	Pulse width	t_{Hsw}	1	-	-	DCLK		
VSYNC	Period	Odd	Note 1	262.5	Note 1	t_H	Note 2	
		Even						
	Display period	Odd	t_{Vdisp}	240				t_H
		Even						
	Back porch	Odd	t_{Vbp}	11	18	24		t_H
		Even		10.5	17.5	23.5		
	Front porch	Odd	t_{Vfp}	0	4.5	-		t_H
		Even		0	5	-		
	Pulse width	Odd	t_{Vsw}	1	-	-		DCLK
		Even						

Note 1: The min and max value of VSYNC period is related to Hsync period and Vs back porch.

Note 2: Please keep frame over 50 Hz to get the better display quality.

e - 2. YUV 720 timing specifications

Parameter		Symbol	Min.	Typ.	Max.	Unit.	Remark	
DCLK Frequency		$1/t_{DCLK}$	16	27	27	MHz		
HSYNC	Period	t_H	1620	1716	1809	DCLK		
	Display period	t_{disp}	1440			DCLK		
	Back porch	t_{hbp}	220	252	283	DCLK		
	Front porch	t_{hfp}	0	24	-	DCLK		
	Pulse width	t_{hsw}	1	20	50	DCLK		
VSYNC	Period	Odd	Note 1	262.5	Note 1	t_H	Note 2	
		Even						
	Display period	Odd	t_{vdisp}	240				t_H
		Even						
	Back porch	Odd	t_{vbp}	11	18	24		t_H
		Even		10.5	17.5	23.5		
	Front porch	Odd	t_{vfp}	0	4.5	-		t_H
		Even		0	5	-		
	Pulse width	Odd	t_{vsw}	1	3	200		DCLK
		Even						

Note 1: The min and max value of VSYNC period is related to Hsync period and Vs back porch.

Note 2: Please keep frame over 50 Hz to get the better display quality.

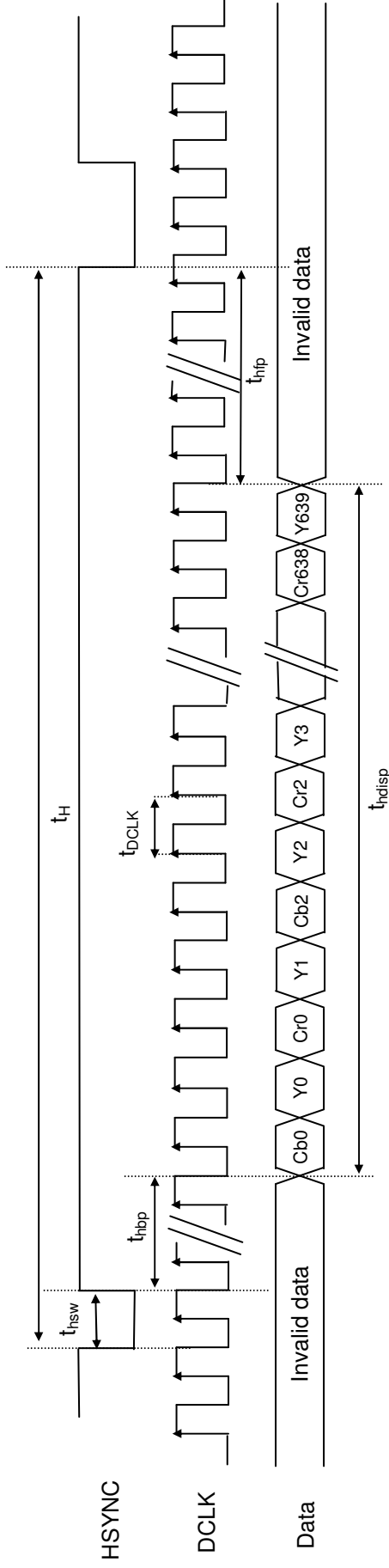

YUV mode A (24.5 MHz) Input Horizontal Signal (SEL = 011)

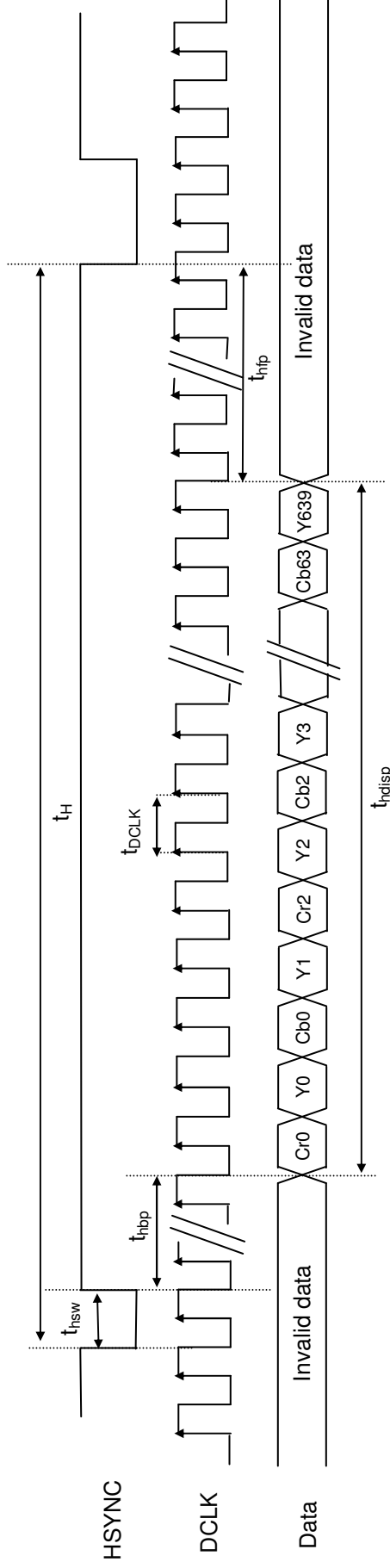

YUV mode B (24.5 MHz) Input Horizontal Signal (SEL = 101)

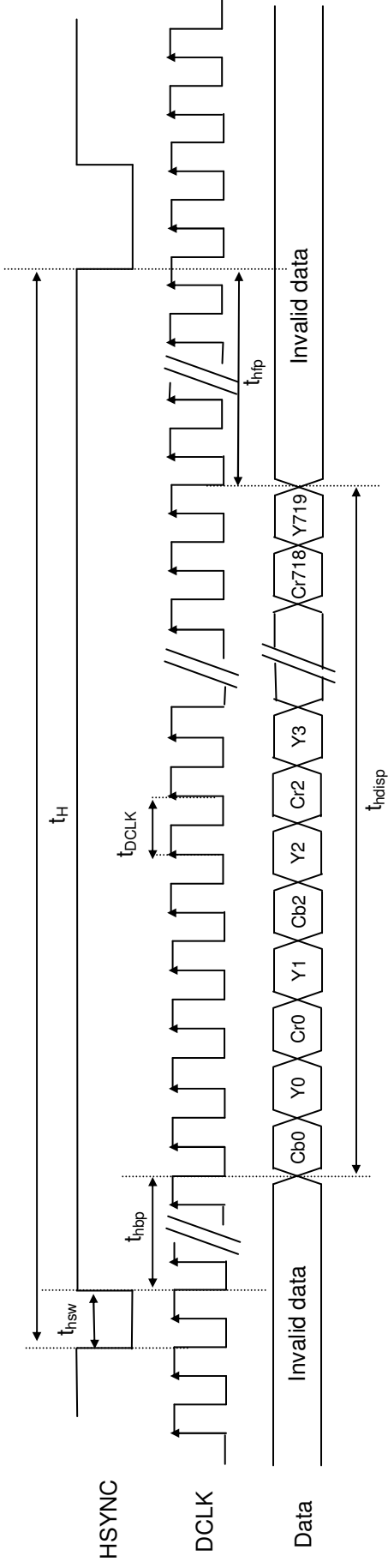

YUV mode A (27 MHz) Input Horizontal Signal (SEL = 100)

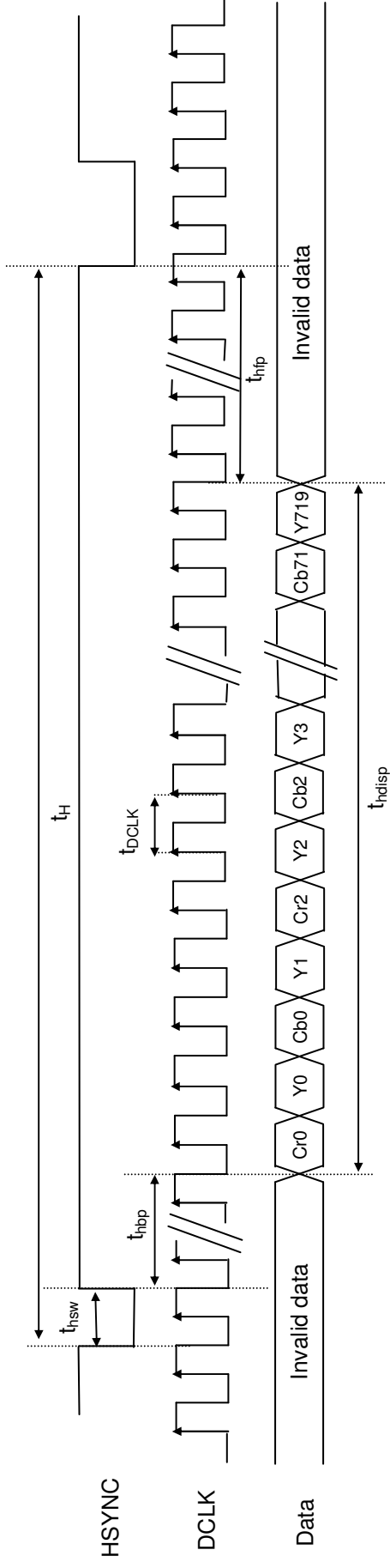

YUV mode B (27MHz) Input Horizontal Signal (SEL = 110)

5. Charge Pump Structure

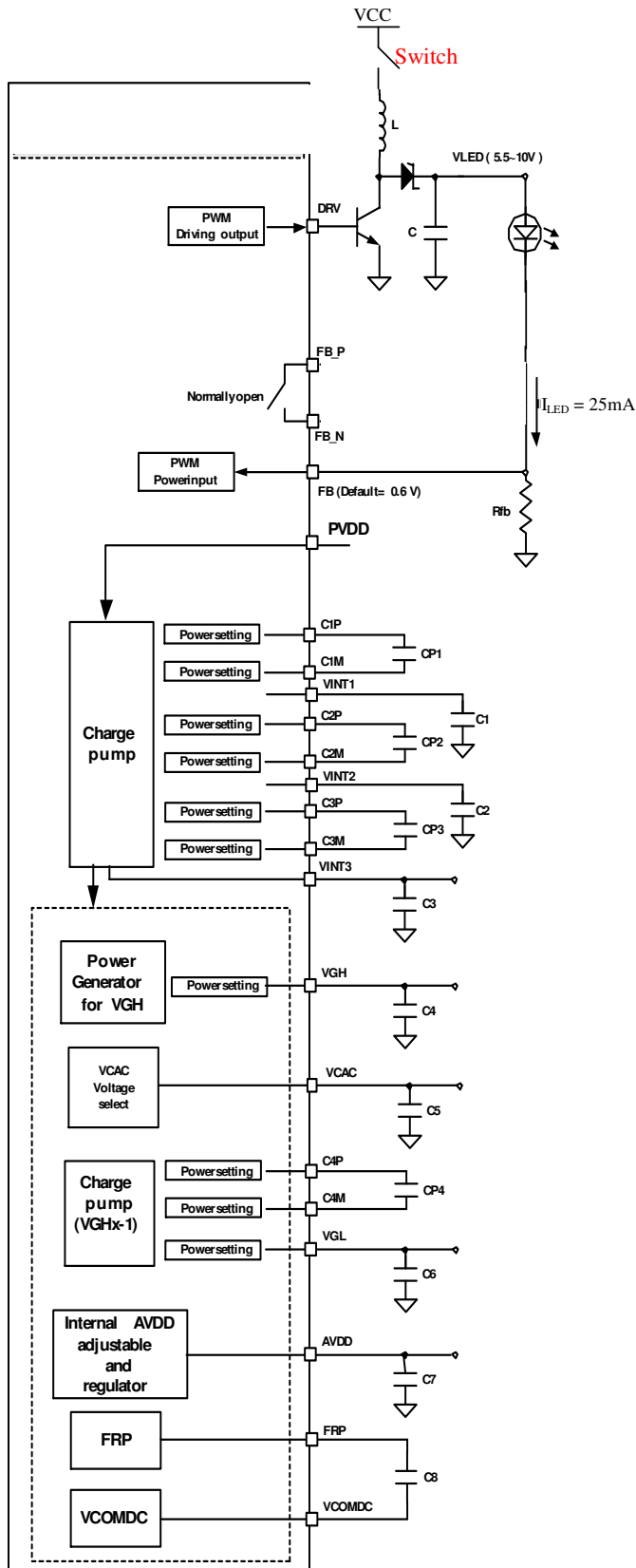

6. Reference Circuit

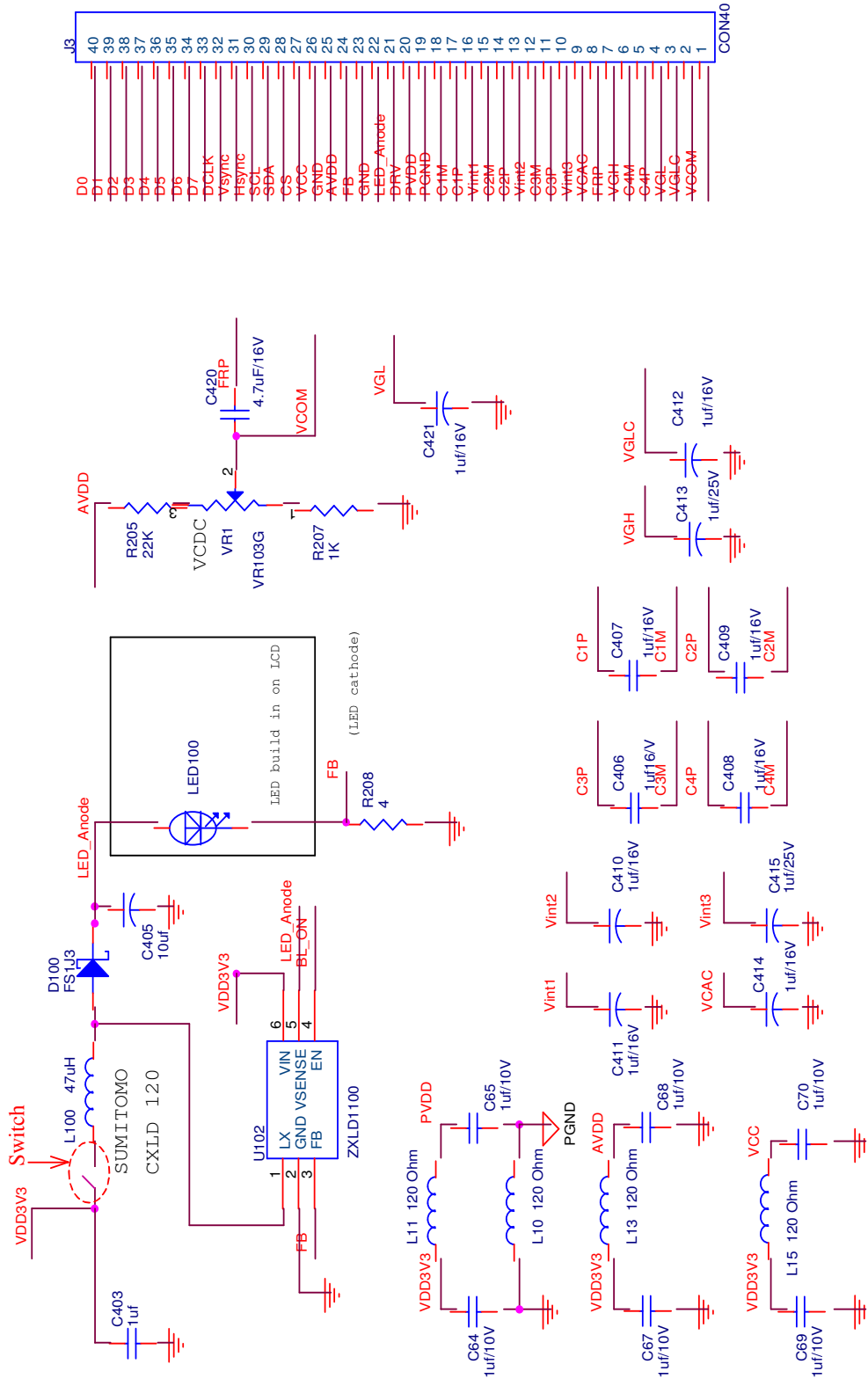

External AVDD + External LED Driver Application Circuit

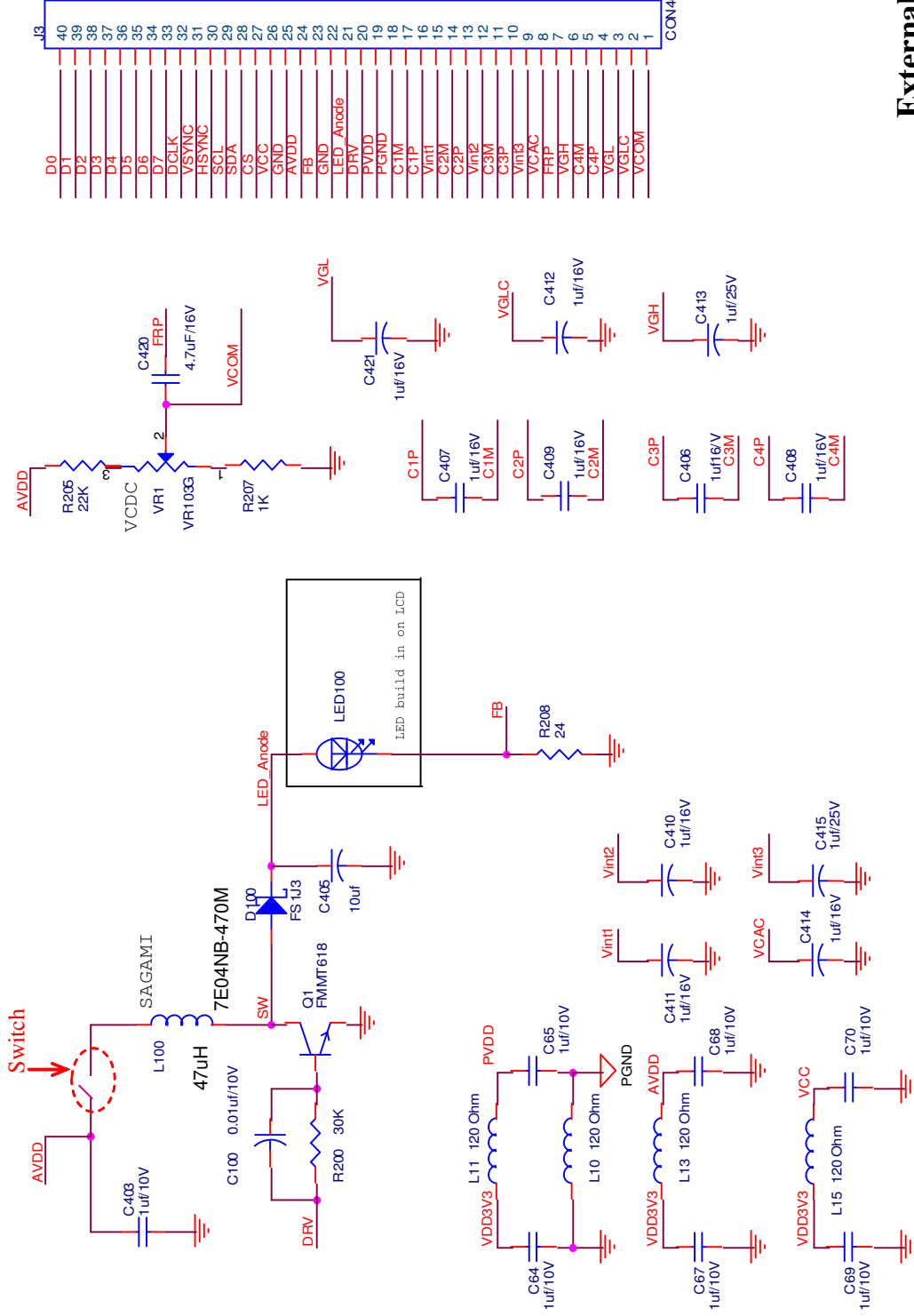

External AVDD +

Internal LED Driver Application Circuit

Note: PWM R/C/L (R200/C100/L100) parameters and component characteristics will effects efficiency

and wave like noise. The application circuit is for reference only. If efficiency is not god or wave like

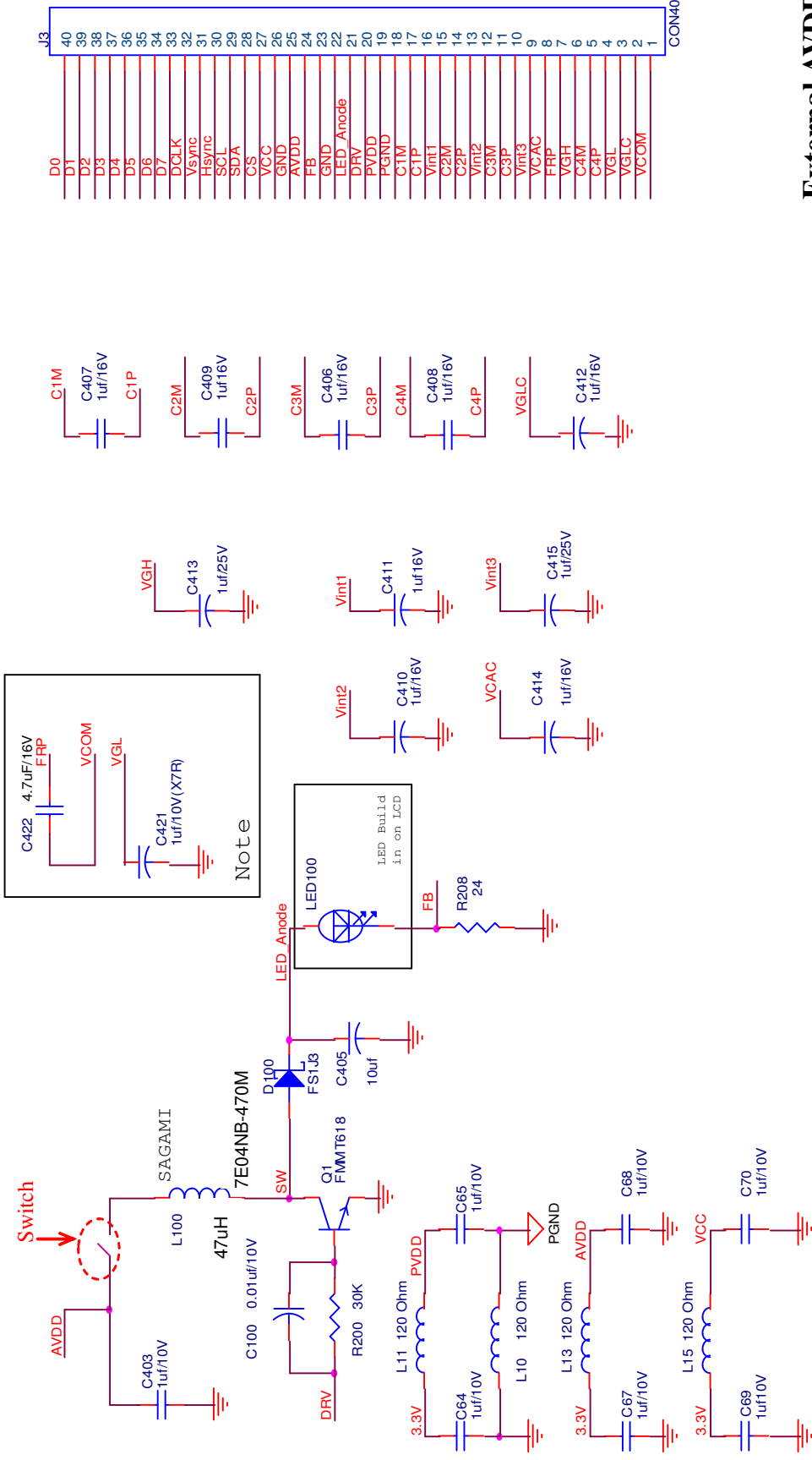

External AVDD

Internal VCOM DC Application Circuit

Note: PWM R/C/L (R200/C100/L100) parameters and component characteristics will effects efficiency and wave like noise. The application circuit is for reference only. If efficiency is not god or wave like noise is serious, please adjust RCL parameters to get best efficiency and display quality

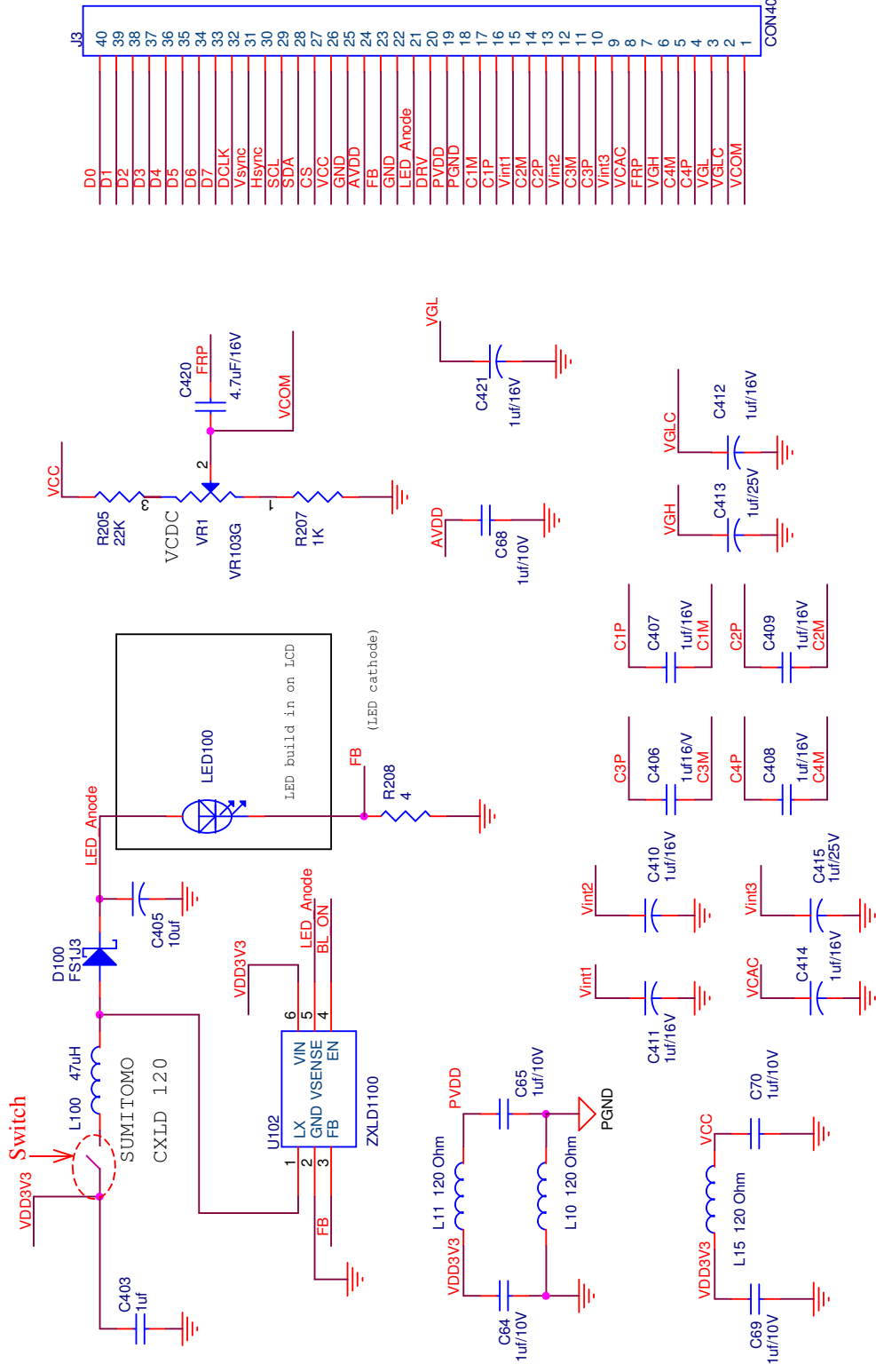

Internal AVDD + External LED Driver Application Circuit

Note : Register T1 Bit 5 (AVDDEN) have to set to '1' when use internal AVDD mode.

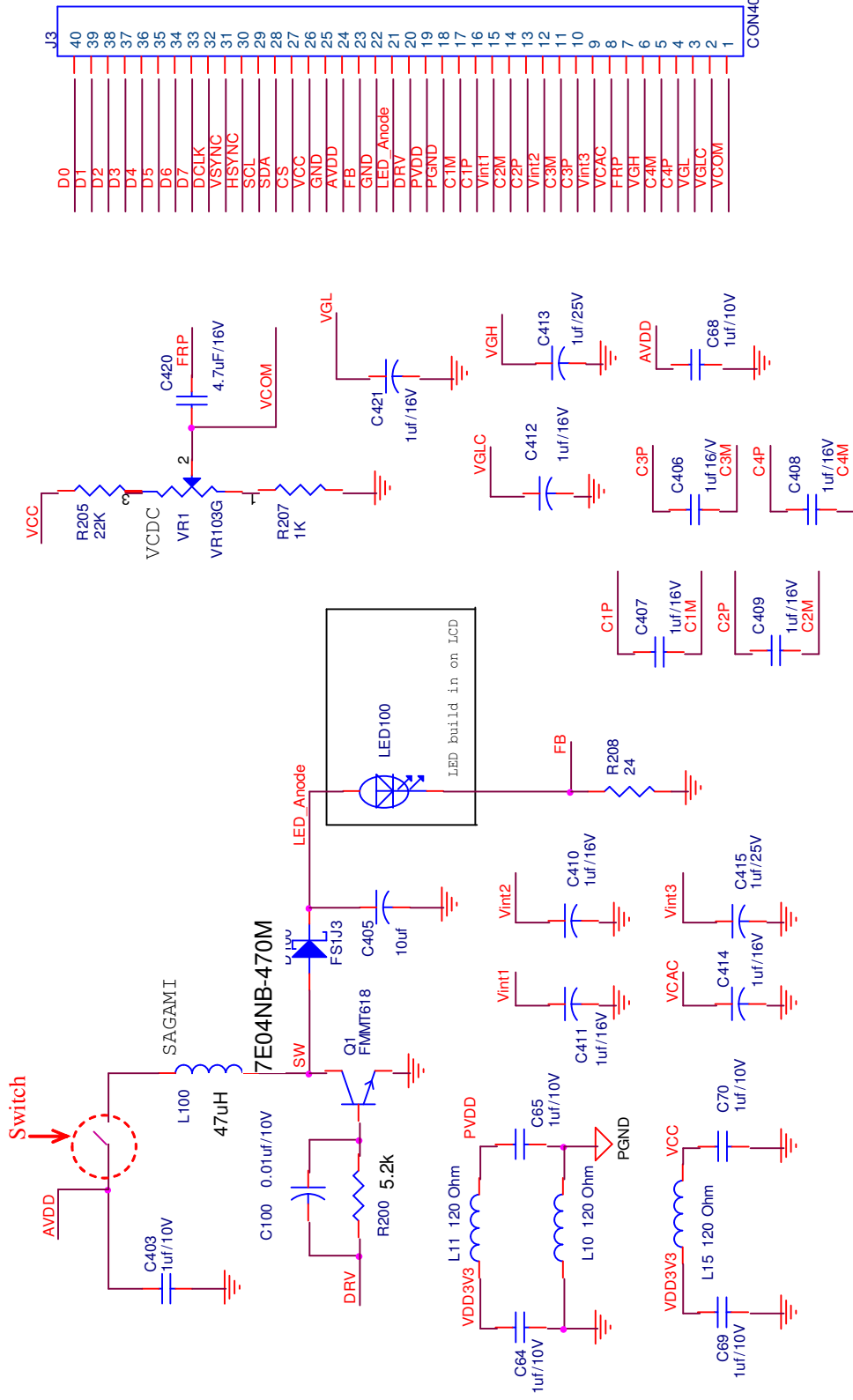

Note 1: PWM R/C/L (R200/C100/L100) parameters and component characteristics will effects efficiency

and wave like noise. The application circuit is for reference only. If efficiency is not god or wave like

noise is serious, please adjust RCL parameters to get best efficiency and display quality

Note 2: Register T1 Bit 5 (AVDDEN) have to set to '1' when use internal AVDD mode.

ALL RIGHTS STRICTLY RESERVED. ANY PORTION OF THIS PRPER SHALL NOT BE REPRODUCED, COPIED, OR TRANSFORMED TO ANY OTHER FORMS WITHOUT PERMISSION FROM AU OPTRONICS CORP.

Internal AVDD + Internal LED Driver Application Circuit

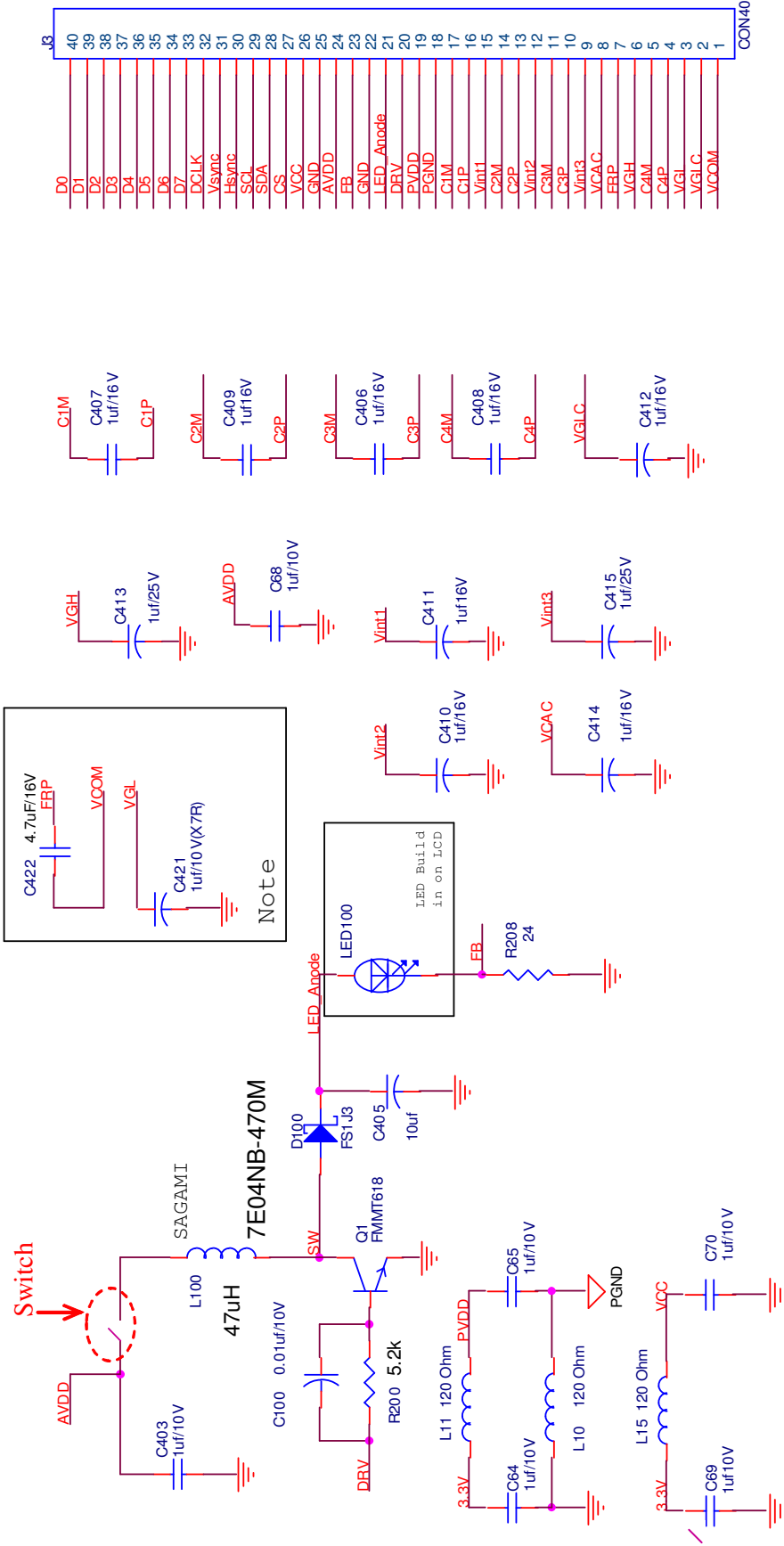

Note 1: PWM R/C/L (R200/C100/L100) parameters and component characteristics will effects efficiency and wave like noise. The application circuit is for reference only. If efficiency is not god or wave like noise is serious, please adjust RCL parameters to get best efficiency and display quality

Note 2: Register T1 Bit 5 (AVDDEN) have to set to '1' when use internal AVDD mode.

Internal AVDD + Internal VCOM DC Application Circuit

7. Serial Interface & Register Table

a. Serial Interface format

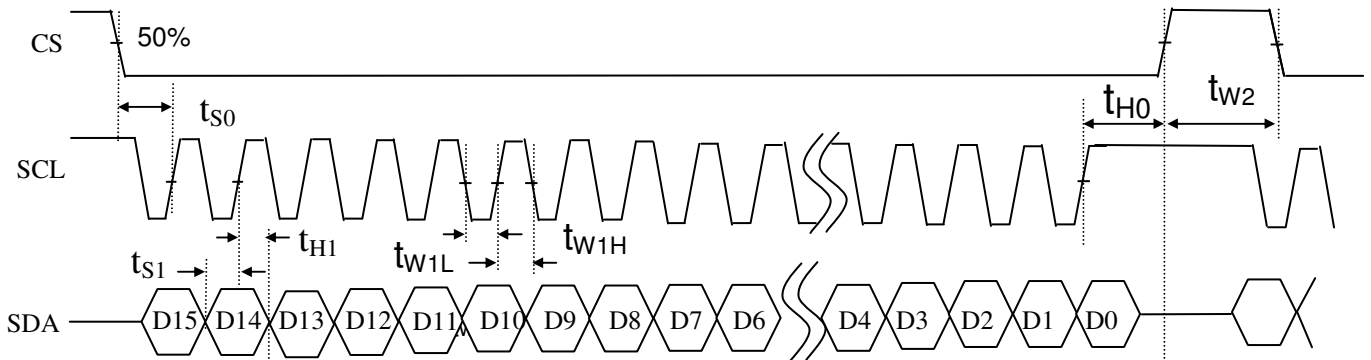

Item	Symbol	Conditions	Min	Typical	Max	Unit
Data Setup Time	t_{S0}	SCL to CS	120			ns
	t_{S1}	SCL to SDA	120			ns
Data Hold Time	t_{H0}	SCL to CS	120			ns
	t_{H1}	SCL to SDA	120			ns
Pulse Width	t_{W1L}	SCL pulse width	120			ns
	t_{W1H}	SCL pulse width	120			ns
	t_{W2}	CS pulse width	1000			ns

b. The configuration of serial data at SDA terminal is at below

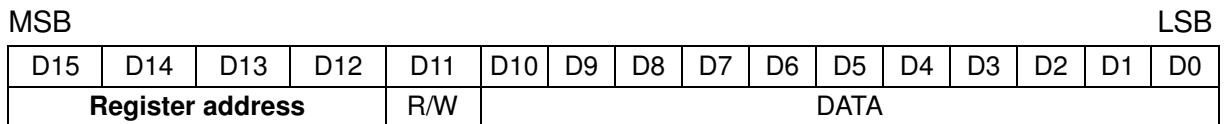

Note: R/W = '0' → Write mode R/W = '1' → Read mode

b1 – Write Mode waveform

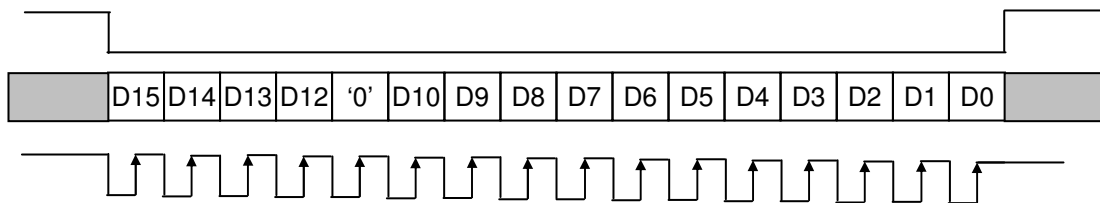

b2 – Read Mode waveform

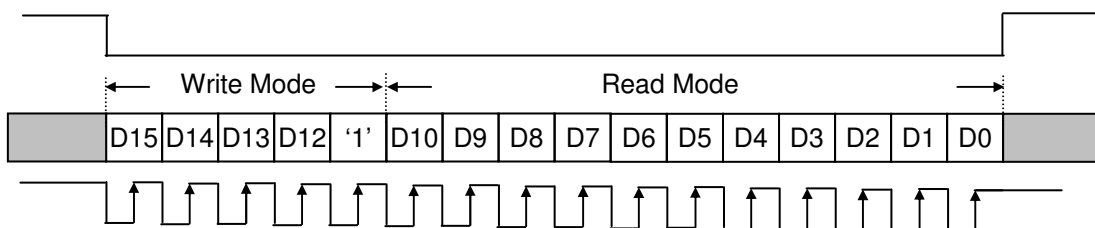



c. Register parameters

No	ADDRESS				R/W	CONTENT								
	D15	D14	D13	D12		D11	D[10 : 8]	D7	D6	D5	D4	D3	D2	D1
R0	0	0	0	0	W	x	x	x	x	x	GRB	STB	SHDB	SHCB
R1	0	0	1	0	W	x	x	x	Reserved			Reserved	PFON	Reserved
R2	0	1	0	0	W	x	x	x	x	x	FPO L	VSET	U/D	SHL
R3	0	1	1	0	W	x	x	x	x	PALM	PAL	SEL		
R4	1	0	0	0	W	x	x	x	x	DDL				
R5	1	0	1	0	W	x	x	x	OEA			HDL		
R6	1	1	0	0	W	x	x	x	x	x	x	VCSL		
R7	1	1	1	0	W	x	x	x	x	GAM SEL	Rese rved	VLNC	AVGY	Reserved
T0	0	0	0	1	W	x	AVDDADJ			PDTY		FBV2	FBV1	FBV0
T1	0	0	1	1	W	x	x	AVG	AVDDEN	T352	CONST			
T2	0	1	0	1	W	x	x	VDCEN	VCOMDC					
T3	0	1	1	1	W	x	x	BRADJ						
T4	1	0	0	1	W	x	x	x	x	x	x	Reversed	VNSEL	
T5	1	0	1	1	W	x	SAT				HUE			
T6	1	1	0	1	R	x	Reserved							

Note 1: Please keep all the Reserved register at “Default Value” to avoid abnormal display.

Note 2: Register T6 is read only.

c1 - Default register settings

No	D15	D14	D13	D12	D11	D[10 : 8]	D7	D6	D5	D4	D3	D2	D1	D0
R0	0	0	0	0	R/W	x	x	x	x	x	1	1	0	1
R1	0	0	1	0	R/W	x	x	x	0	0	0	0	0	1
R2	0	1	0	0	R/W	x	x	x	x	x	0	0	1	1
R3	0	1	1	0	R/W	x	x	x	x	0	0	0	0	1
R4	1	0	0	0	R/W	x	x	x	x	0	0	0	0	0
R5	1	0	1	0	R/W	x	x	x	0	0	0	0	0	0
R6	1	1	0	0	R/W	x	x	x	x	x	x	1	1	0
R7	1	1	1	0	R/W	x	x	x	x	0	0	0	1	1
T0	0	0	0	1	R/W	x	0	0	0	0	0	1	0	0
T1	0	0	1	1	R/W	x	x	0	0	0	1	0	0	0
T2	0	1	0	1	R/W	x	x	0	1	0	0	0	0	0
T3	0	1	1	1	R/W	x	x	1	0	0	0	0	0	0
T4	1	0	0	1	R/W	x	x	x	x	x	x	0	0	0
T5	1	0	1	1	R/W	x	1	0	0	0	1	0	0	0
T6	1	1	0	1	R	x	Reserved							

“X” => Don't care.

d. Detail Register Description

d1. Register R0

Address	Bit	Description		Default
0000	[3..0]	Bit3 (GRB)	Global reset.	1101b
		Bit2 (STB)	Standby mode setting.	
		Bit1 (SHDB)	DC-DC converter shutdown setting.	
		Bit0 (SHCB)	Charge Pump shutdown setting.	

Bit3	GRB function
0	The controller is resets, the charge pump and DCDC is off. Reset all register to default value.
1	Normal operation. (default)

Bit2	STB function
0	T-CON, source driver and DC-DC converter are off. All outputs are High-Z.
1	Normal operation. (default)

Bit1	SHDB function
0	DC-DC converter is off. (default)
1	DC-DC converter is on. DC-DC controls by STB and power on/off sequence.

Bit0	SHCB function
0	Charge Pump converter is off.
1	Charge Pump converter is on. (default) Charge Pump controls by STB and power on/off sequence.

d2. Register R1:

Address	Bit	Description		Default
0010	[5..0]	Reserved	Reserved	00_0001b
		Reserved	Reserved	
		Bit1 (PFON)	Pre-filter setting.	
		Bit0 (D/S)	Select Delta or Stripe mode for Data arrangement.	

Bit1	Pre-filter setting.
0	Pre-filter off (default)
1	Pre-filter on

Bit0	D/S function
0	Stripe mode. Q1H always stays High. Data alignment always odd line.
1	Delta mode Q1H toggles each line. Data alignment switches between Odd/even lines. (default)

d3. Register R2:

Address	Bit	Description		Default
0100	[3..0]	Bit3 (FPOL)	FRP source driver polarity inversion polarity inversion selection.	0011b
		Bit2 (VSET)	Selects between internal or external references for gamma correction. (For Test only, please keep this bit L)	
		Bit1 (U/D)	Vertical shift direction selection.	
		Bit0 (SHL)	Horizontal shift direction selection.	

Bit3	FPOL function
0	FRP=0 when positive polarity FRP=1 when negative polarity (default)
1	FRP=1 when positive polarity FRP=0 when negative polarity

Bit1	UD function
0	Scan down: First line=G241 → G239 → ... → G2 → Last line=G0.
1	Scan up: First line=G0 → G2 → ... → G239 → Last line=G241. (default)

Bit0	SHL function
0	Shift left; First data=S640 → S639 → ... → S2 → Last data=S1.
1	Shift right: First data=S1 → S2 → ... → S639 → Last data=S640. (default)

d4. Register R3:

Address	Bit	Description		Default
0110	[4..0]	Bit4 (PALM)	PAL 1/6, PAL1/6,8 selection.	1_0001b
		Bit3 (PAL)	PAL/NTSC selection.	
		Bit2-0 (SEL)	Input data format selection.	

Bit4	PALM function
0	PAL 1/6,8 Input format. (280 active line).
1	PAL1/6 Input format. (288 active line). (default)

Bit3	PAL function
0	NTSC Input format (240 active line). (default)
1	PAL Input format.

Bit2-0	SEL function
000	UPS051 path, special data format: DDX.
001	UPS052 320RGB 24.54MHz data format. (default)
010	UPS052 360RGB 27MHz data format.
011	YUV mode A 640Y 320CrCb 24.54MHz data format.
100	YUV mode A 720Y 360CrCb 27MHz data format.
101	YUV mode B 640Y 320CrCb 24.54MHz data format.
110	YUV mode B 720Y 360CrCb 27MHz data format.
111	CCIR 656 720Y 360CrCb 27MHz data format.



d5. Register R4:

Address	Bit	Description	Default
1000	[4..0]	Bit4-0 (DDL) Horizontal Data start delay selection.	0_0000b

D4	D3	D2	D1	D0	Value	Unit
0	0	0	0	0	+0	DCLK
0	0	0	0	1	+1	
0	0	0	1	0	+2	
0	0	0	1	1	+3	
0	0	1	0	0	+4	
0	0	1	0	1	+5	
0	0	1	1	0	+6	
0	0	1	1	1	+7	
0	1	0	0	0	+8	
0	1	0	0	1	+9	
0	1	0	1	0	+10	
0	1	0	1	1	+11	
0	1	1	0	0	+12	DCLK
0	1	1	0	1	+13	
0	1	1	1	0	+14	
0	1	1	1	1	+15	
1	0	0	0	0	-1	
1	0	0	0	1	-2	
1	0	0	1	0	-3	
1	0	0	1	1	-4	
1	0	1	0	0	-5	
1	0	1	0	1	-6	
1	0	1	1	0	-7	
1	0	1	1	1	-8	
1	1	0	0	0	-9	
1	1	0	0	1	-10	
1	1	0	1	0	-11	
1	1	0	1	1	-12	
1	1	1	0	0	-13	
1	1	1	0	1	-14	
1	1	1	1	0	-15	
1	1	1	1	1	-16	

d6. Register R5:

Address	Bit	Description	Default
1010	[5..0]	Bit5-4 (OEA)	Odd Even advance selection.
		Bit3-0 (HDL)	Vertical delay selection.
			00_0000b

Bit5-4	OEA function
00	Display start @HDL delay for Odd and Even field (default)
01	Display start @HDL delay for Odd field and @HDL+1 for Even field
1X	Display start @HDL+1 delay for Odd field and @HDL+1 for Even field

Bit3-0		HDL function				Unit
HDL3	HDL2	HDL1	HDL0	Value		
0	0	0	0	+0	H	
0	0	0	1	+1		
0	0	1	0	+2		
0	0	1	1	+3		
0	1	0	0	+4		
0	1	0	1	+5		
0	1	1	0	+6		
0	1	1	1	+7		
1	0	0	0	+8		
1	0	0	1	-1		
1	0	1	0	-2		
1	0	1	1	-3		
1	1	0	0	-4		
1	1	0	1	-5		
1	1	1	0	-6		
1	1	1	1	-7		

d7. Register R6:

Address	Bit	Description	Default
1100	[2..0]	Bit2-0 (VCOM_AC) VCAC level adjustment. Step 0.2V/LSB.	110b

VCSL2	VCSL1	VCSL0	VCAC level	Unit
0	0	0	6.2	V
0	0	1	6.4	
0	1	0	5.0	
0	1	1	5.2	
1	0	0	5.4	
1	0	1	5.6	
1	1	0	5.8 (Default)	
1	1	1	6.0	

d8. Register R7:

Address	Bit	Description	Default	
1110	[4..0]	Bit4 (GAMSEL)	Gamma select function	0_0011
		Reserved	Reserved	
		Bit2 (VLNC)	YUV vertical line function	
		Bit1 (AVGY)	Average YUV interface Luminance Y setting	
		Bit0 (DMDA)	Delta data alignment	

Bit4	Gamma select function
0	Non- Linear Gamma (default)
1	Gamma 2.2

Bit2	YUV vertical line function
0	Vertical line are 240 (default)
1	Vertical line are 234 NTSC: 240 lines scaling to 234-skip 6 lines. (1/40) PAL: 288 lines scaling to 234-skip 54 lines (3/16) @ PALM = 'H' 280 lines scaling to 234-skip 46 lines (1/6) @ PALM = 'L'

Bit1	Average YUV interface Luminance Y setting
0	Only used odd Y sample for YUV conversion
1	Used odd and even Y sample for YUC conversion (default)

Bit0	Delta data alignment
0	Data alignment by default setting
1	Data alignment please reference UPS052 timing graph II. (default) (This function disable in UPS051 mode.)

d9. Register T0:

Address	Bit	Description	Default	
0001	[7..0]	Bit5-7 (AVDDADJ)	Select internal AVDD voltage	0000_0100b
		Bit3-4 (PDTY)	PWM duty control for DC to DC converter	
		Bit2-0 (FBV)	FB voltage adjust	

Bit 5- 7	Select internal AVDD voltage
000	3.3V (default)
001	3.5V
010	3.7V
011	3.9V
100	4.1V
101	4.3V
110	4.5V
111	4.7V

Bit3-4	PWM duty control for DC to DC converter
00	75 %(Default)
01	55 %
10	60 %
11	65 %

Bit2-0	FB voltage adjust
000	0.4V
001	0.45V
010	0.5V
011	0.55V
100	0.6V (Default)
101	0.65V
110	0.7V
111	0.75V

d10. Register T1:

Address	Bit	Description		Default
0011	[6..0]	Bit6 (AVG)	Data alignment to scaling down function select	000_1000b
		Bit5 (AVDDEN)	Enable internal AVDD	
		Bit4 (T352)	Select UPS052 path and input data format for 352 RGB	
		Bit3-0 (CONST)	RGB contrast level adjustment	

Bit6	Data alignment to scaling down function select
0	Data alignment by DMDA settling (Default)
1	Data alignment with averaged and input data.(R1, (G1+3G2)/4, (3B2+B3)/4.....)

Bit5	Enable internal AVDD
0	Select external AVDD(Default)
1	Select internal AVDD

Bit4	Select UPS052 path and input data format for 352 RGB
0	SEL setting timing (Default)
1	SEL setting don't care, input data for 352 RGB(27MHZ)

Bit3-0	RGB contrast level adjustment
0x0	0
0x8	1.00 (Default)
0xF	1.875

d11. Register T2:

Address	Bit	Description		Default
0101	[6..0]	Bit6 (VDCEN)	Setting FRP output to add DC level	010_0000b
		Bit5-0 (VCOM DC)	VCOM DC level adjustment (16mV/Bit)	

Bit6	Setting FRP output to add DC level
0	External VCOM DC
1	Internal VCOM DC

Bit5-0	VCOM DC level adjustment
0x00	0.188V
0x20	0.7V (Default)
0x3F	1.196V

d12. Register T3:

Address	Bit	Description		Default
0111	[6..0]	Bit6-0 (BRADJ)	Brightness level adjustment (4/Bit)	100_0000b

Bit6	Brightness level adjustment
0x00	-256
0x40	0 (Default)
0x7F	+256



d13. Register T4:

Address	Bit	Description		Default
1001	[2..0]	Reserved	Reserved	000b
		Bit1-0 (WNSEL)	Wide and narrow display select	

Bit1-0	Wide and narrow display select
00	Normal display (Default)
01	Narrow display
10	Wide display
11	Normal display

d14. Register T5:

Address	Bit	Description		Default
1011	[7..0]	Bit7-4 (SAT)	YUV saturation constant adjustment (0.125/Bit)	1000_1000b
		Bit3-0 (HUE)	YUV Hue adjustment (5Deg/Bit)	

Bit7-4	YUV saturation constant adjustment
0x0	0
0x8	1.00
0xF	1.875

Bit3-0	YUV Hue adjustment (5Deg/Bit)
0x0	-40 θ°
0x8	0 θ°
0xF	35 θ°

Note: Register T5 is for YUV only.

C. Optical specification (Note 1, Note 2, Note 3)

Item	Symbol	Condition	Min.	Typ.	Max.	Unit	Remark
Response time	Rise	$\theta = 0^\circ$	-	15	25	ms	Note 4, 6
	Fall		-	30	40	ms	
Contrast ratio	CR	At optimized viewing angle	150	250	-		Note 5, 6
Viewing angle	Top	$CR \geq 10$	10	15	-	deg.	Note 6, 7
	Bottom		30	35	-		
	Left		40	45	-		
	Right		40	45	-		
Brightness		$\theta = 0^\circ$	200	250	-	nits	
White chromaticity shift	X	$\theta = 0^\circ$	(0.27)	(0.31)	(0.35)		
	y		(0.29)	(0.33)	(0.37)		

Note 1. Ambient temperature =25°C.

Note 2. To be measured in the dark room.

Note 3. To be measured on the center area of panel with a field angle of 1° by Topcon luminance meter BM-7, after 10 minutes operation under 25 mA.

Note 4. Definition of response time:

The output signals of photo detector are measured when the input signals are changed from "black" to "white"(falling time) and from "white" to "black"(rising time), respectively.

The response time is defined as the time interval between the 10% and 90% of amplitudes. Refer to figure as below.

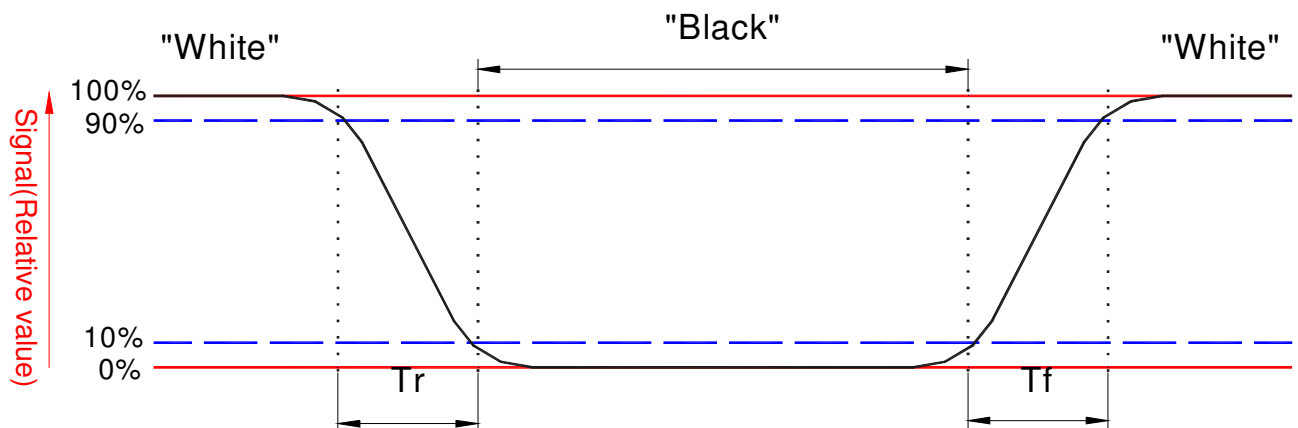

Note 5. Definition of contrast ratio:

Contrast ratio is calculated with the following formula.

$$\text{Contrast ratio (CR)} = \frac{\text{Photo detector output when LCD is at "White" state}}{\text{Photo detector output when LCD is at "Black" state}}$$

Note 6. White $V_i = V_{i5} + 1.5V$

Black $V_i = V_{i50} \pm 2.0V$

“±” Means that the analog input signal swings in phase with COM signal.

“+” Means that the analog input signal swings out of phase with COM signal.

V_{i50} : The analog input voltage when transmission is 50%

The 100% transmission is defined as the transmission of LCD panel when all the input terminals of module are electrically opened.

Note 7. Definition of viewing angle:

Refer to figure as below.

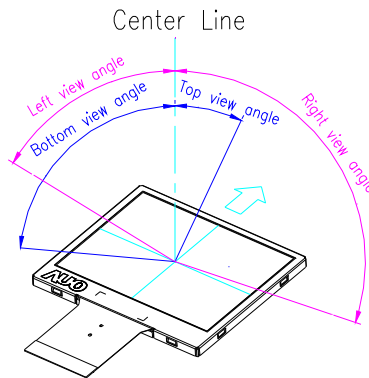

Note 8. CF Arrangement

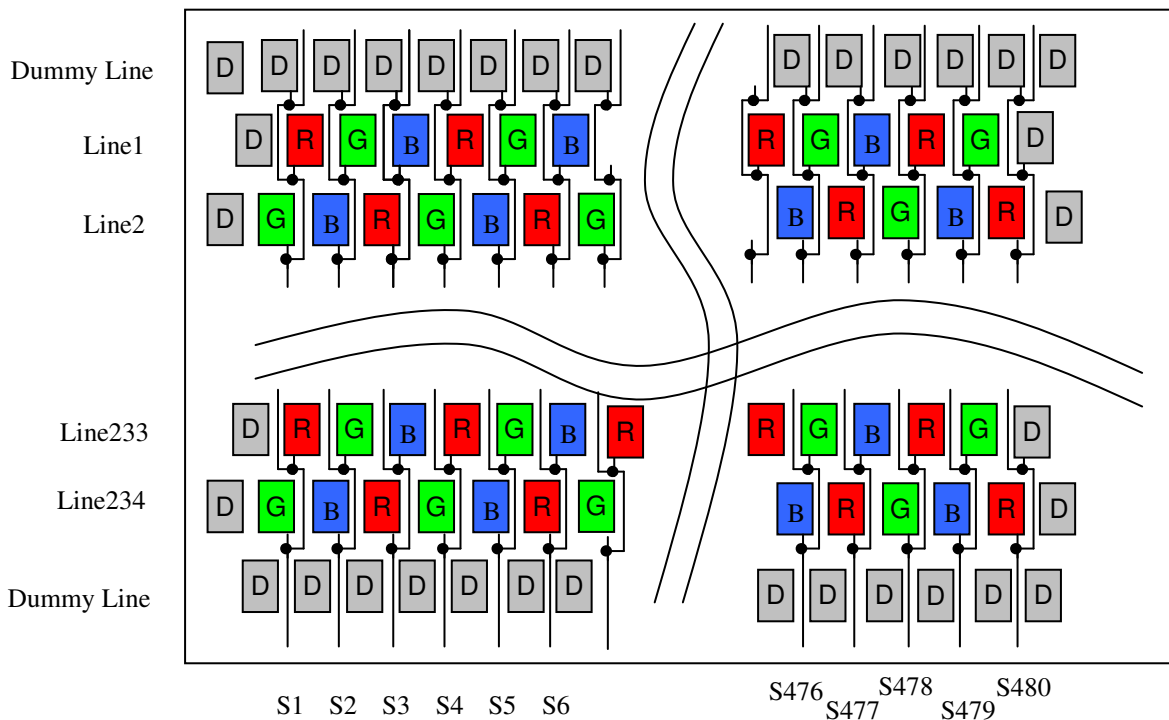

D. Reliability test items:

No.	Test items	Conditions	Remark
1	High temperature storage	Ta= 70°C 240Hrs	
2	Low temperature storage	Ta= -25°C 240Hrs	
3	High temperature operation	Ta= 60°C 240Hrs	
4	Low temperature operation	Ta= 0°C 240Hrs	
5	High temperature and high humidity	Ta= 60°C . 90% RH 240Hrs	Operation
6	Heat shock	-25°C ~80°C /50 cycle 2Hrs/cycle	Non-operation
7	Electrostatic discharge	±200V,200pF(0Ω), once for each terminal	Non-operation
8	Vibration (with carton)	Random vibration: 0.015G ² /Hz from 5~200Hz -6dB/Octave from 200~500Hz	IEC 68-34
9	Drop (with carton)	Height: 60cm 1 corner, 3 edges, 6 surfaces	

Note: Ta: Ambient temperature.

E. Packing form

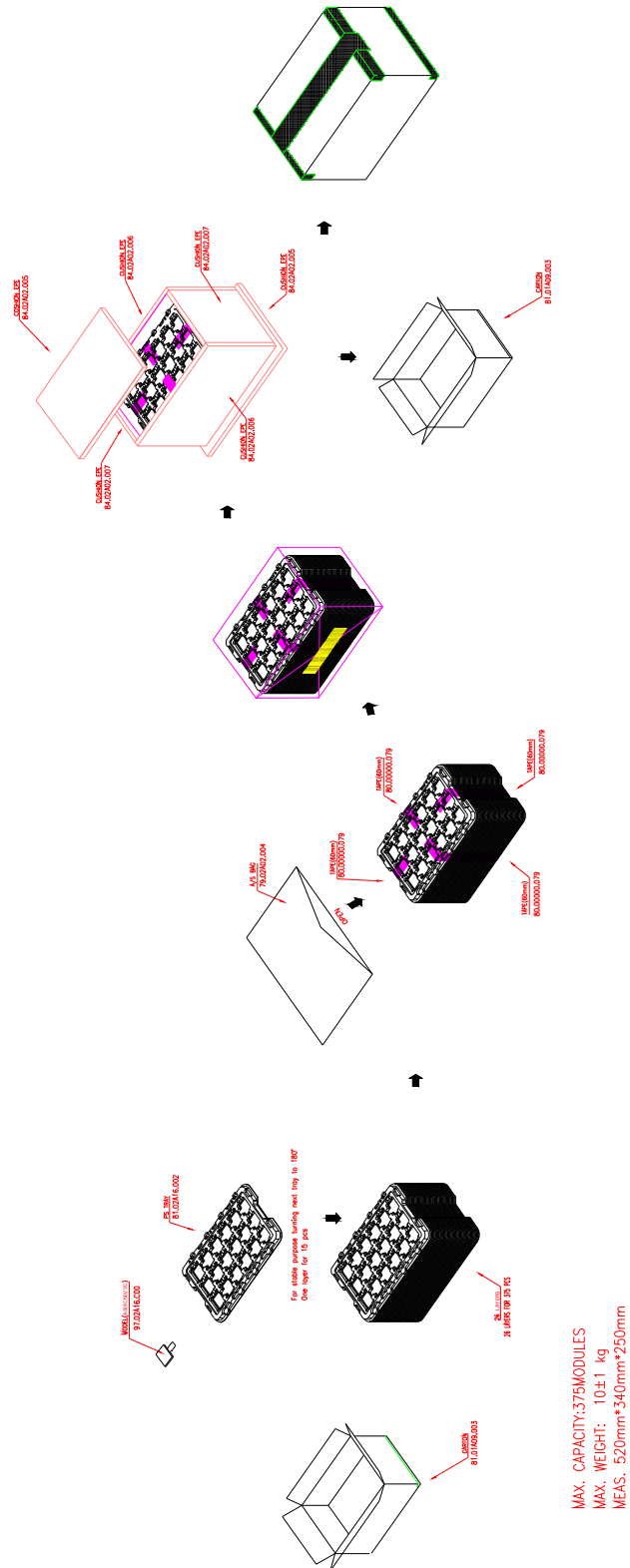

F. Outline dimension

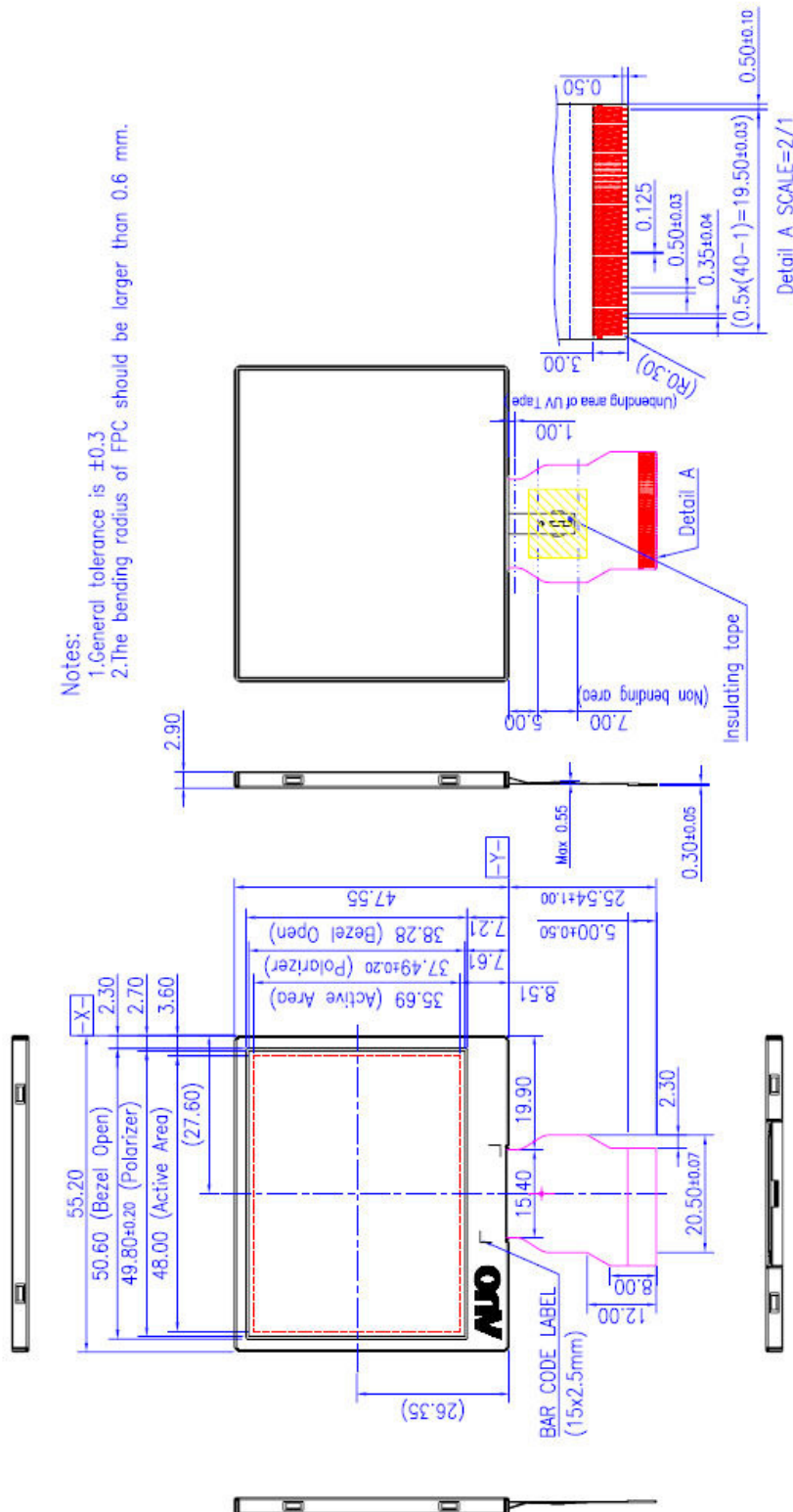

Fig. 1 Outline dimension of TFT-LCD module

“To avoid applying pressure or stress on the products. These will cause visual defects or luminance non-uniformity on the lighting area.”

G. Application Notes

1. Stand-by timing

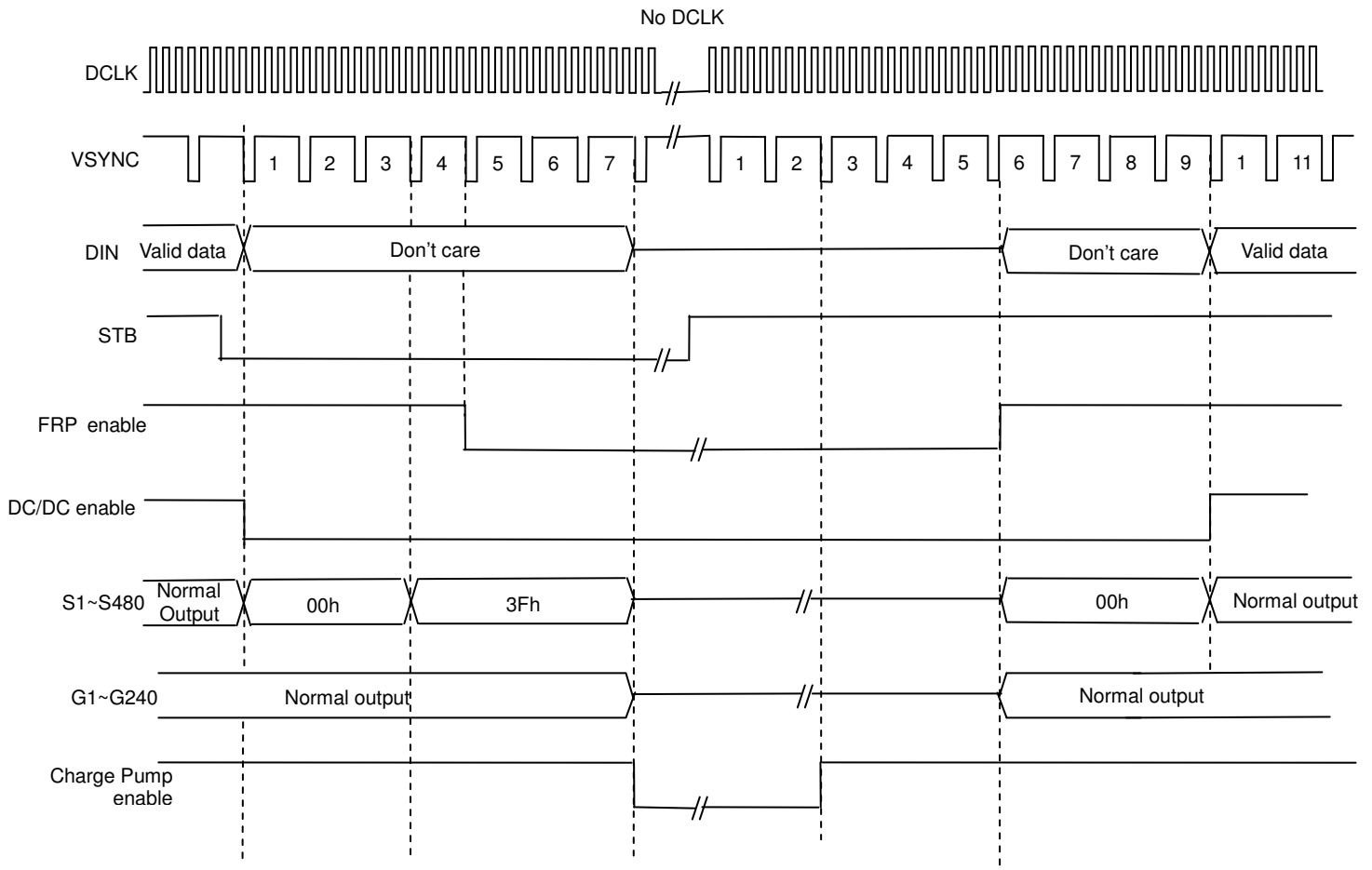

Fig. 2: Stand-by timing diagram

Note 1: During No DCLK, HSYNC and VSYNC can be stopped. But in all other cases HSYNC and VSYNC must be active.

Note 2: External signal: DCLK, VSYNC, DIN (D0 ~ D7), STB (By register)

Internal signal: DC/DC enable S1 ~ S480 (Source Driver output signal), FRP enable

G1 ~ G240 (Gate Driver output signal) and Charge Pump enable.

2. Power on sequence

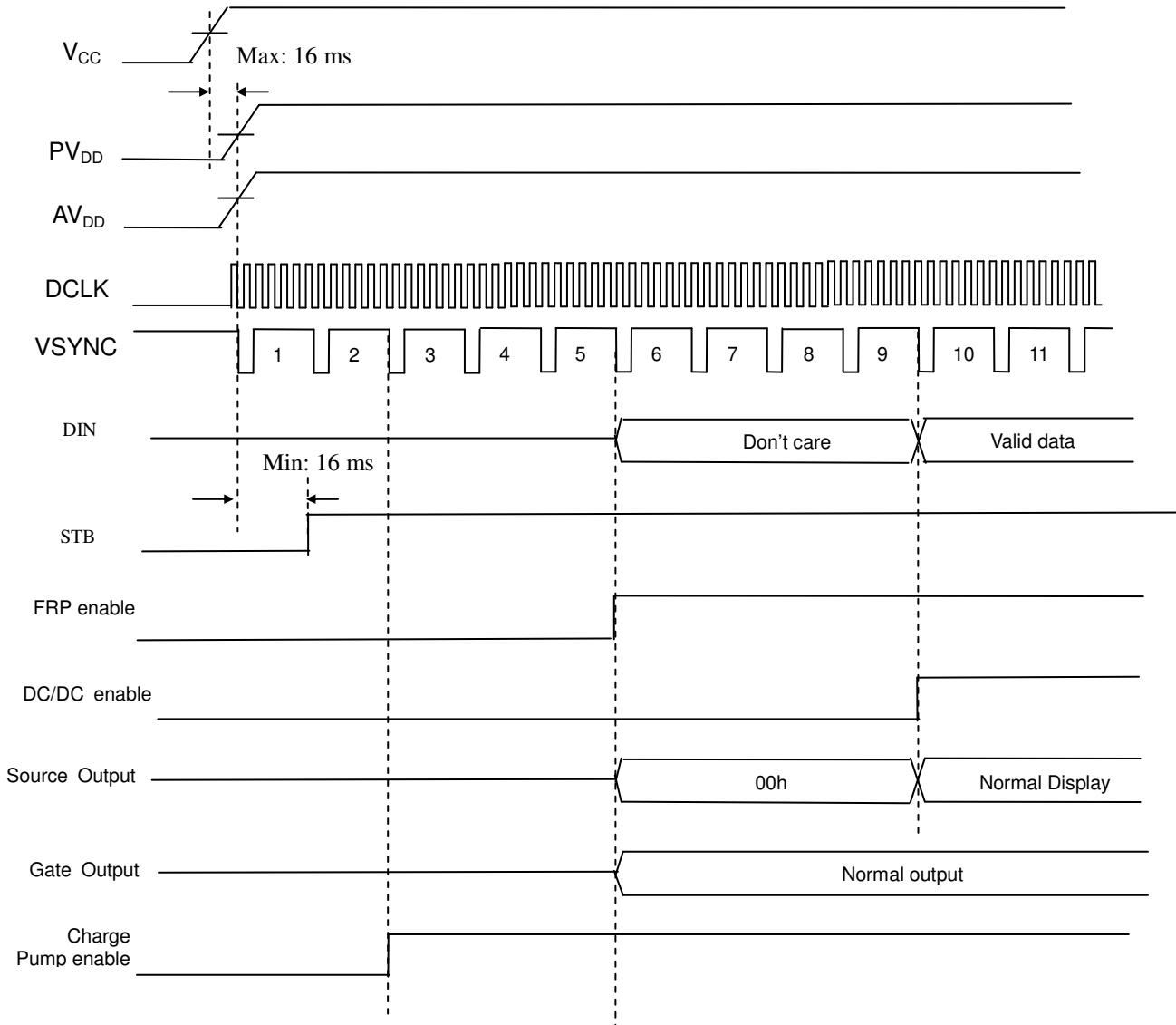

Note 1: External signal: V_{CC}, PV_{DD}, AV_{DD}, DCLK, VSYNC, DIN (D0 ~ D7), STB (By register)
 Internal signal: DC/DC enable S1 ~ S480 (Source Driver output signal), FRP enable,
 G1 ~ G240 (Gate Driver output signal) and Charge Pump enable.

3. Power off sequence - 1

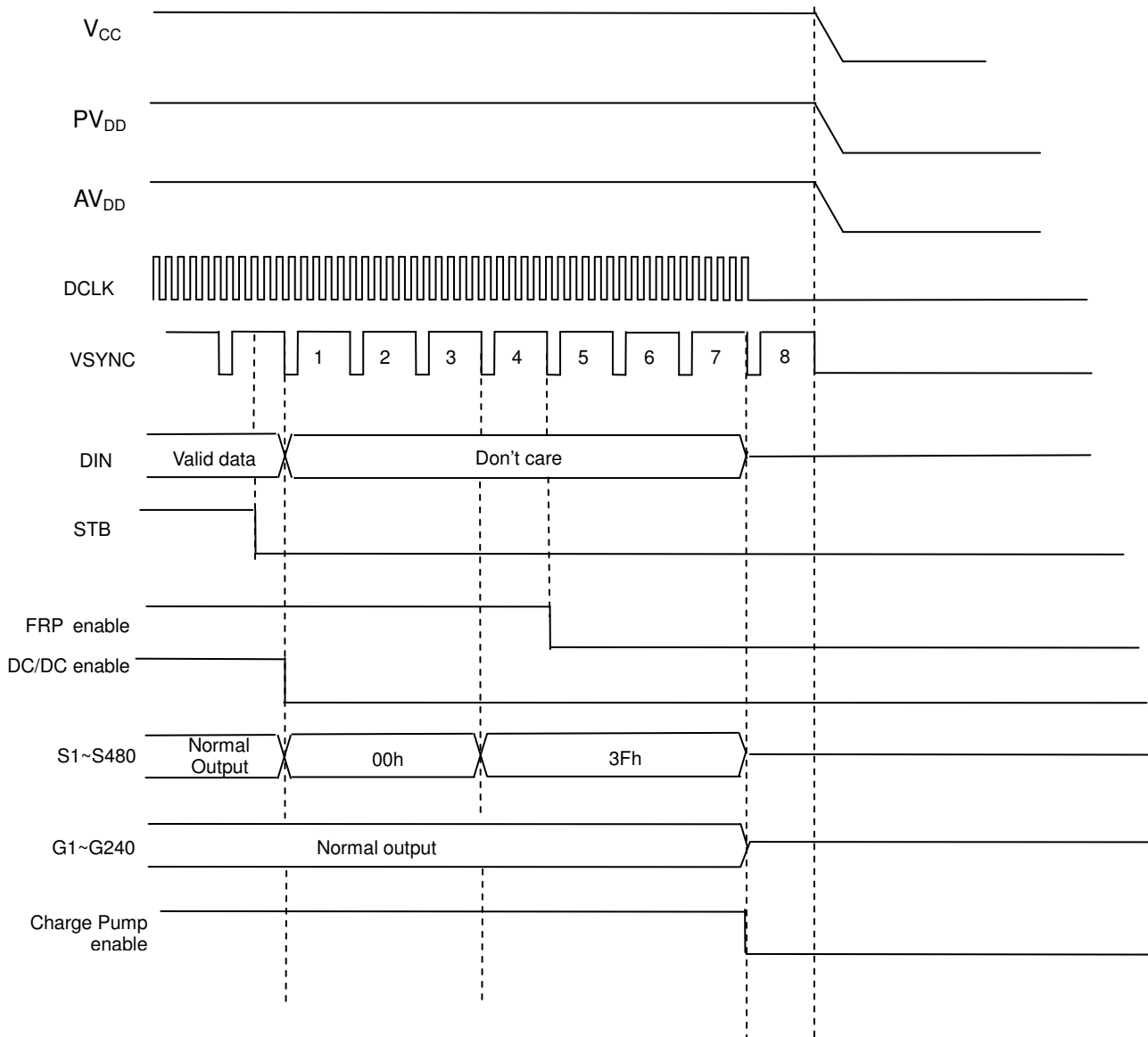

Note 1: External signal: V_{CC}, PV_{DD}, AV_{DD}, DCLK, VSYNC, DIN (D0 ~ D7), STB (By register)
 Internal signal: DC/DC enable S1 ~ S480 (Source Driver output signal), FRP enable,
 G1 ~ G240 (Gate Driver output signal) and Charge Pump enable.

4. Recommended power on/off serial command settings

In this LCD driver, we must set the command three times during power on. The method of setting must follow Fig.3, and the three times of command setting must be the same.

Fig. 3 LCD serial command setting during power on

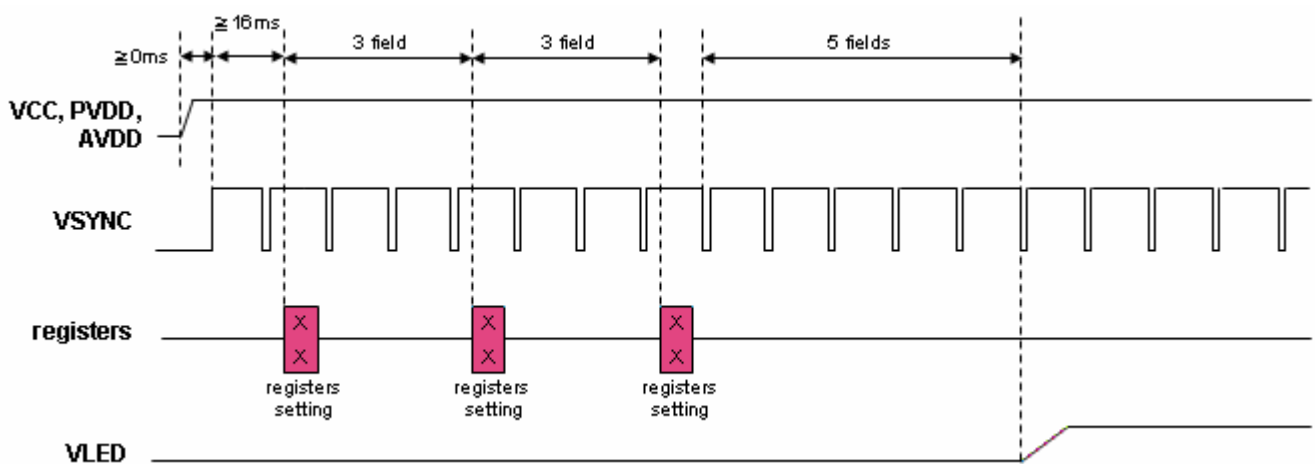

Note 1: Under different input timing, the register setting can reference next section.

4.1. Recommend UPS051 (9.7 MHz) power on/off setting

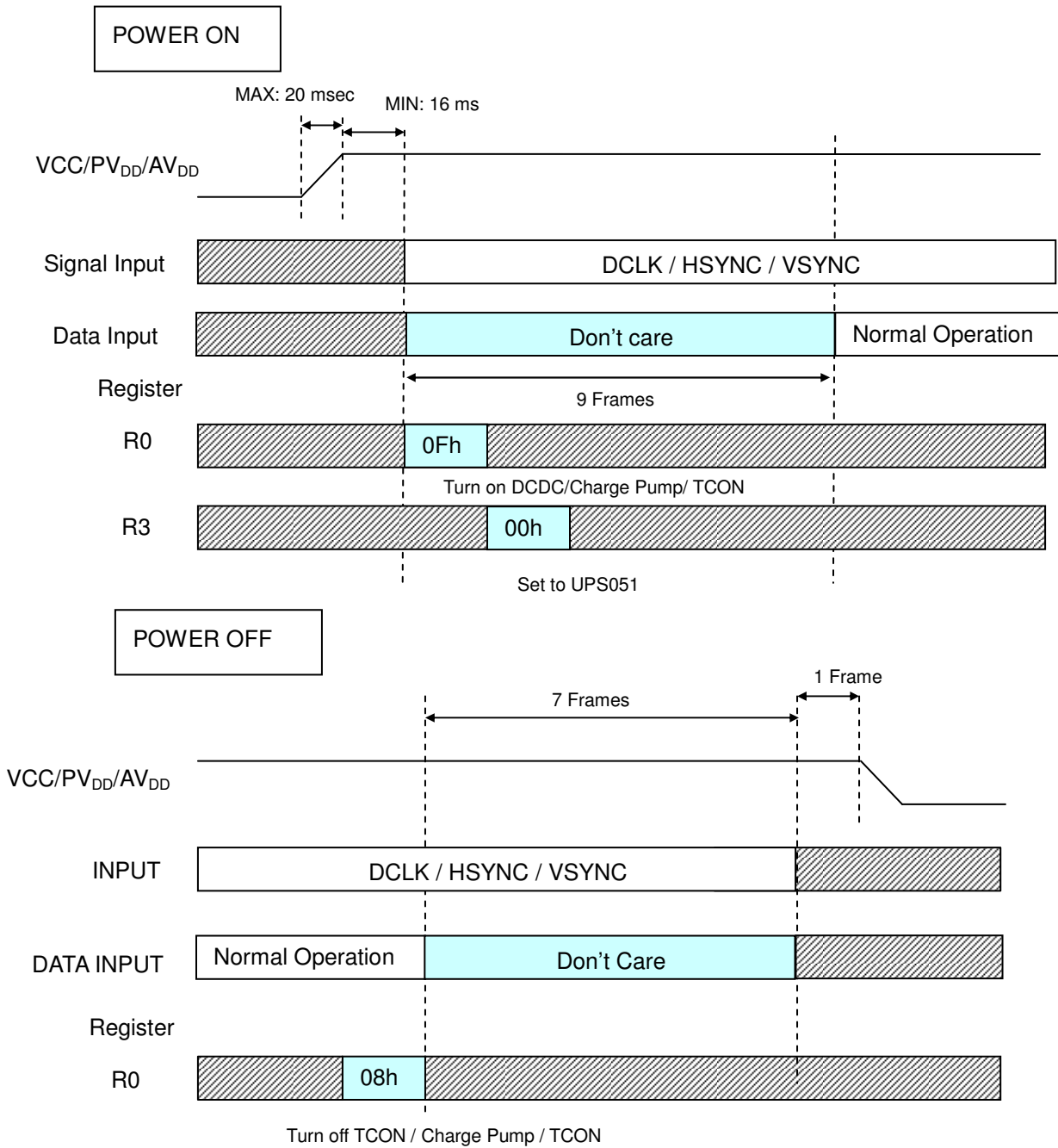

4.2. Recommend UPS052 320RGB mode (24.54 MHz) power on/off setting

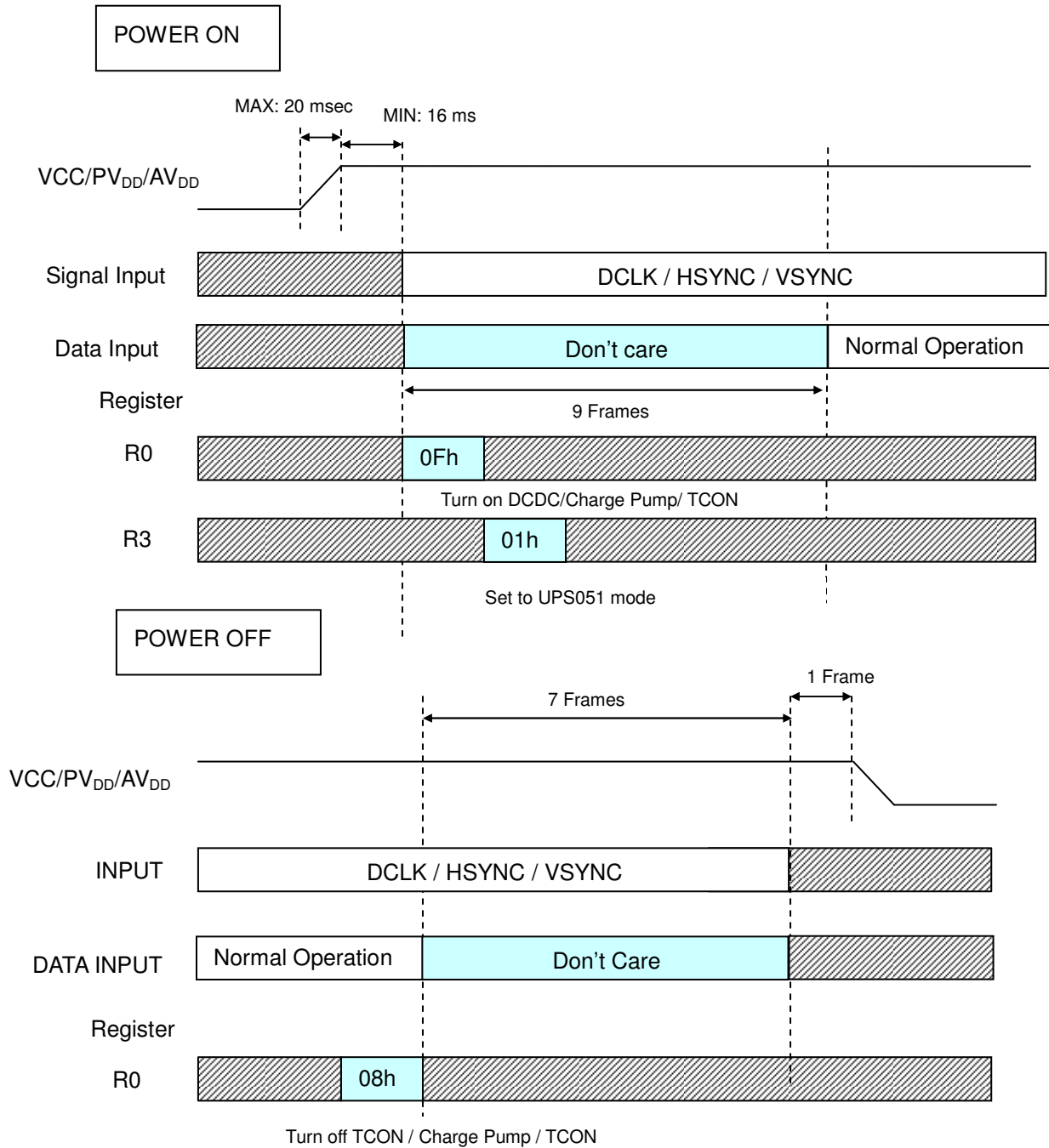

4.3. Recommend UPS052 360RGB mode (27MHz) power on/off setting

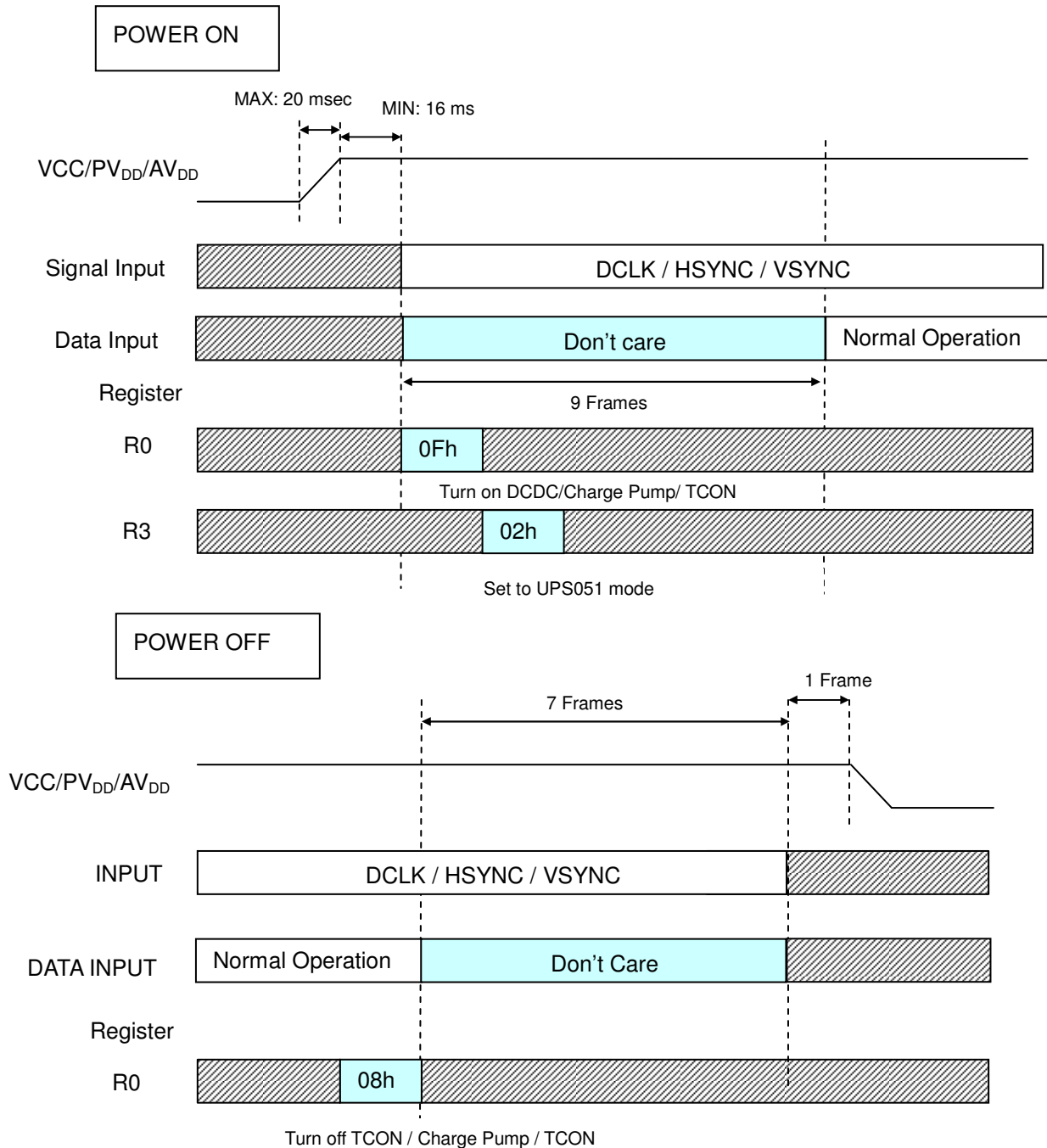

4.4. Recommend YUV mode A 640Y 320CrCb (24.54 MHz) power on/off setting

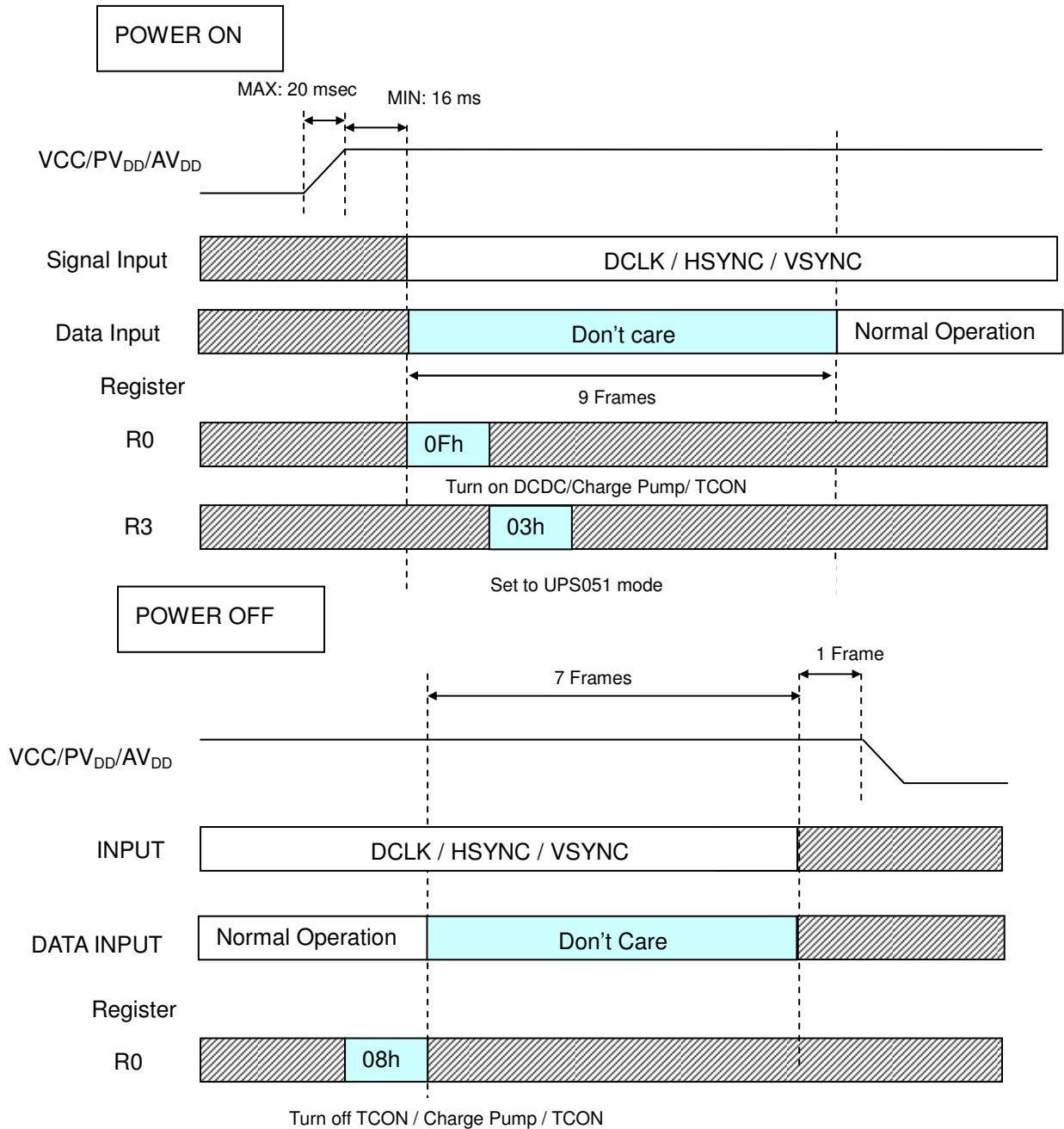

4.5. Recommend YUV mode A 720Y 360CrCb (27 MHz) power on/off setting

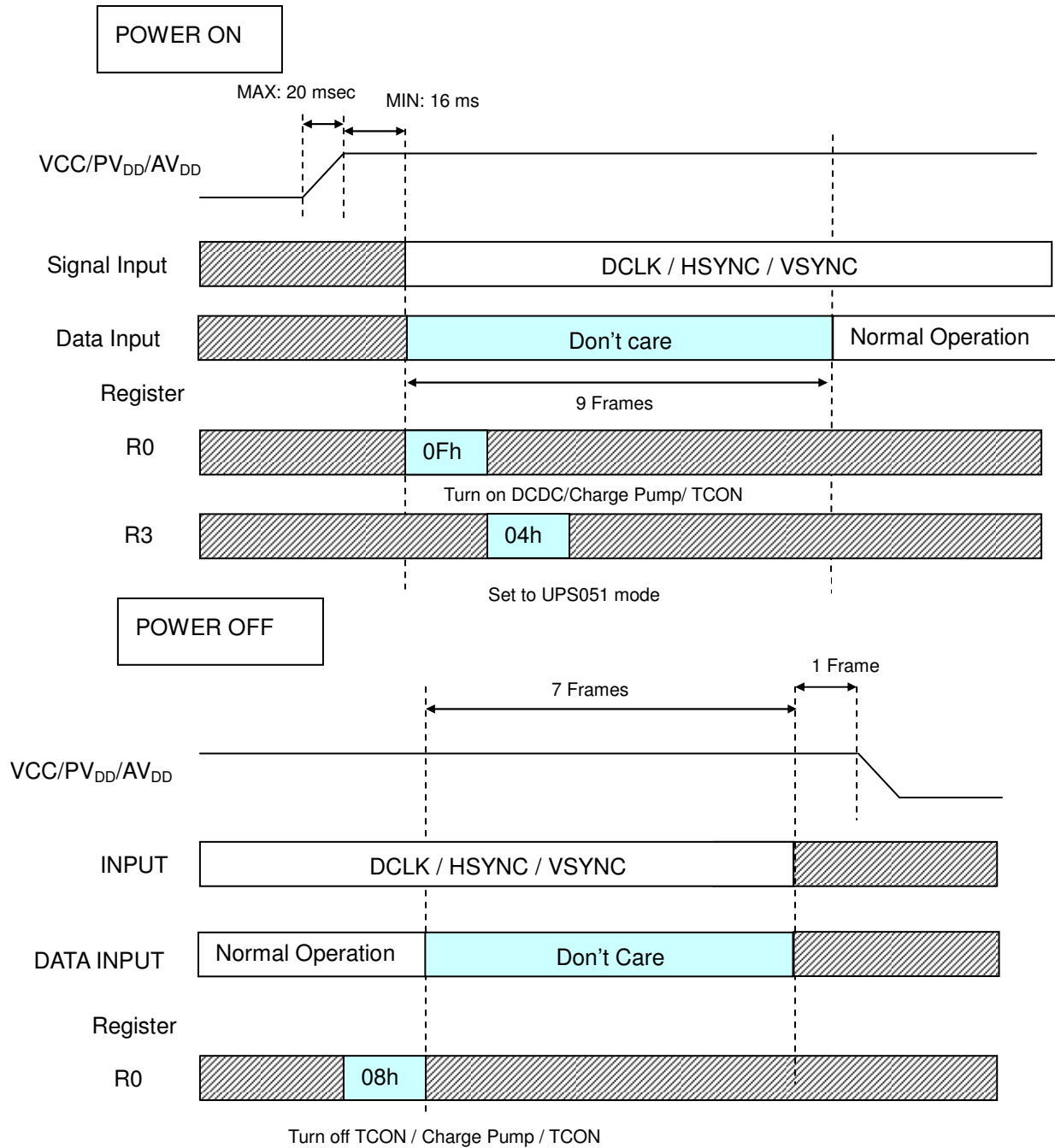

4.6. Recommend YUV mode B 640Y 320CrCb (24.54 MHz) power on/off setting

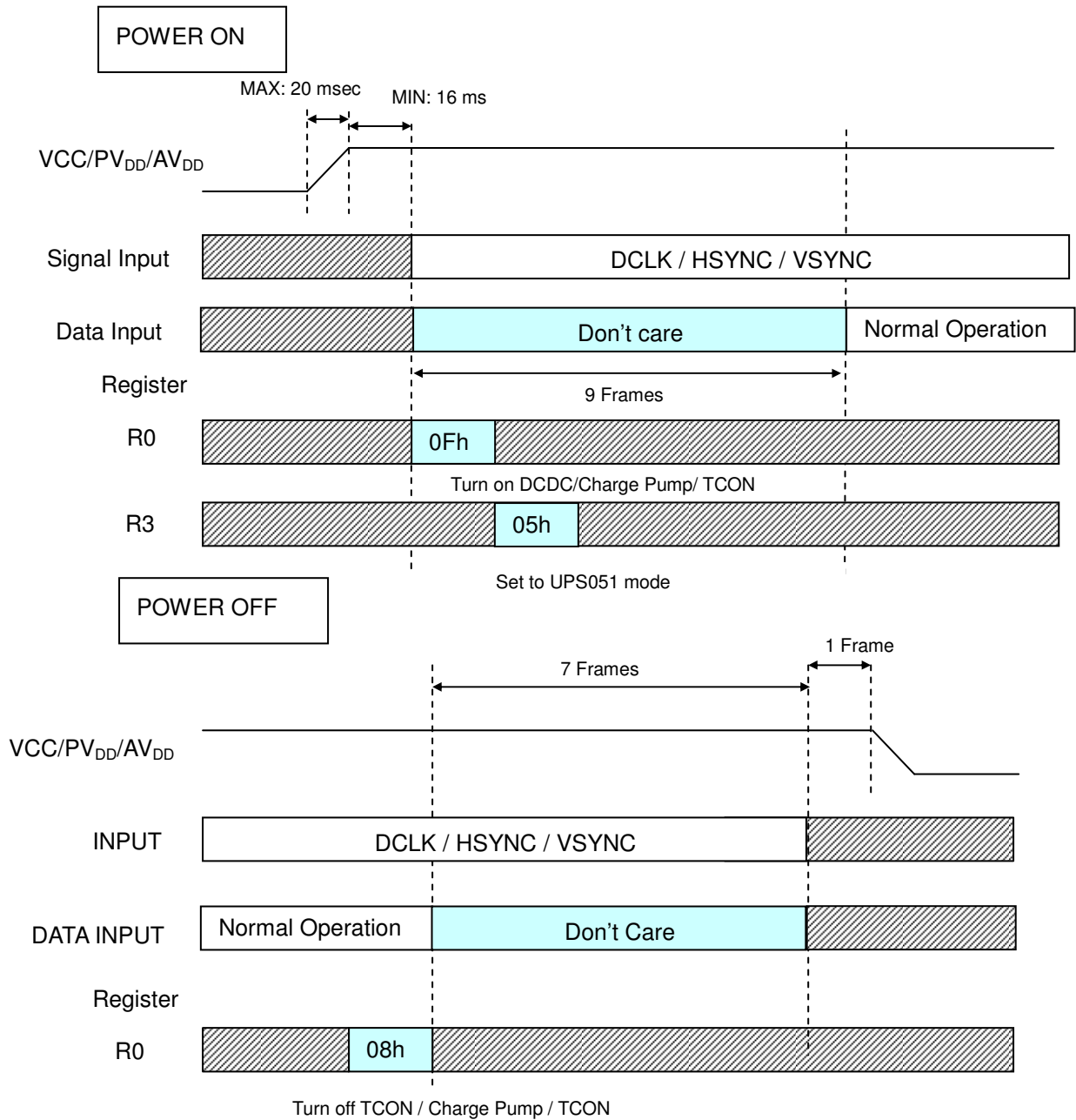

4.7. Recommend YUV mode B 720Y 320CrCb (27 MHz) power on/off setting

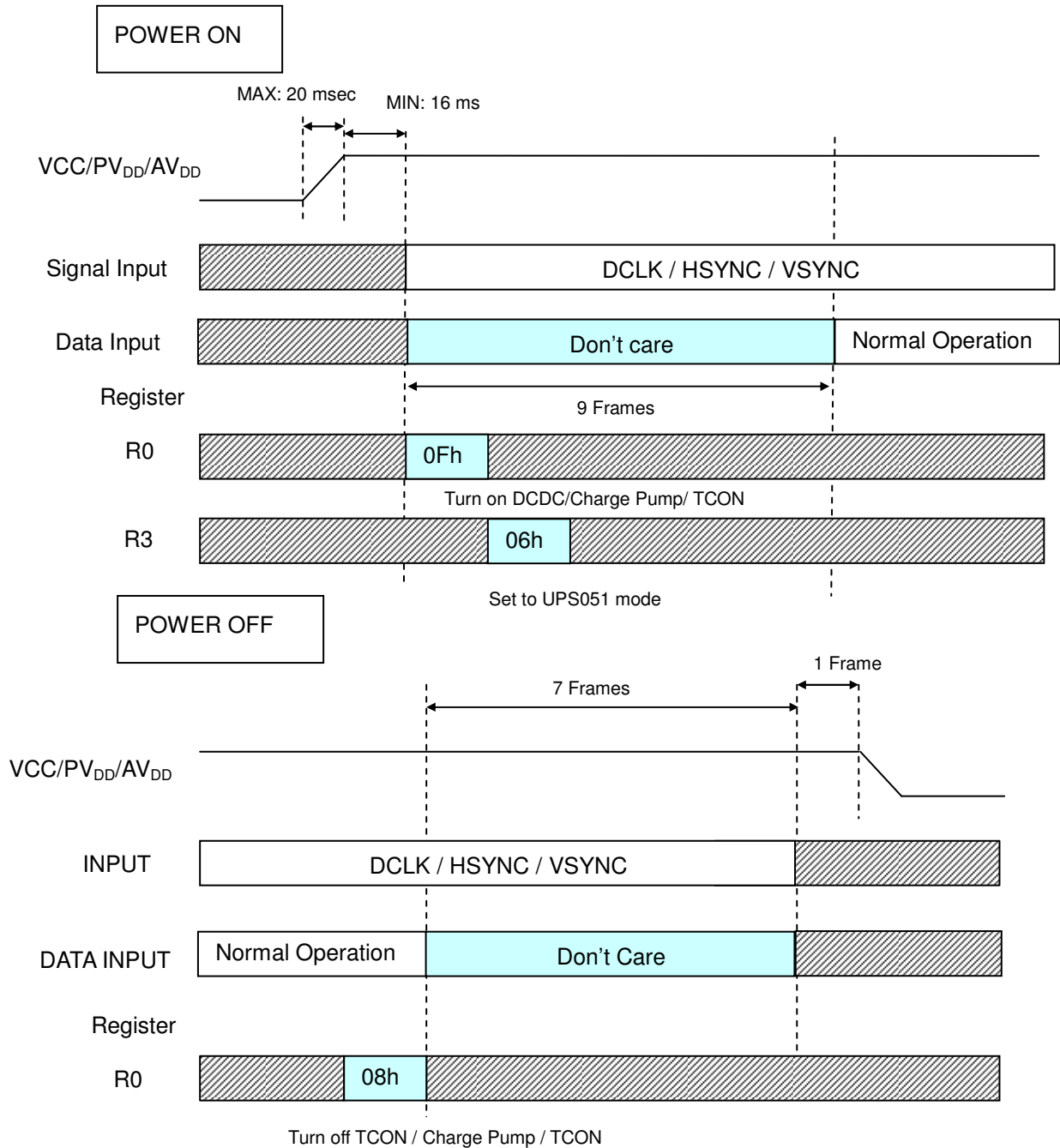

4.8. Recommend CCIR656 mode (27 MHz) power on/off setting

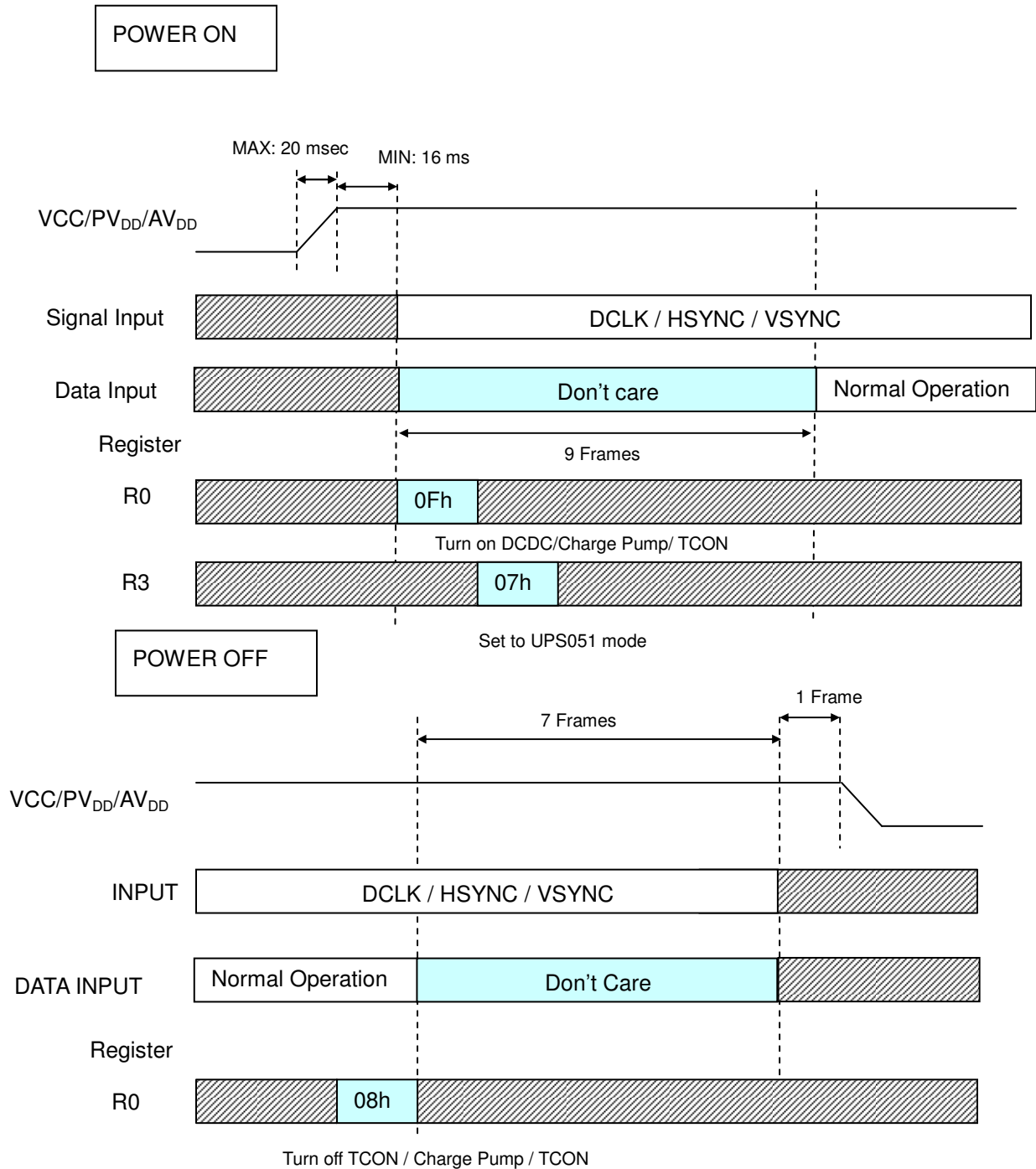

5 The Difference between This model and Previous models (A024CN02 V0 ~ V8, VA)

a. VCOM DC setting

Because the structure of ASIC is different between the new model and original model, so AUO suggest customer adjust VCOM DC value from $0.45V \pm 0.2$ to $0.5V \pm 0.2$ to get best display quality.

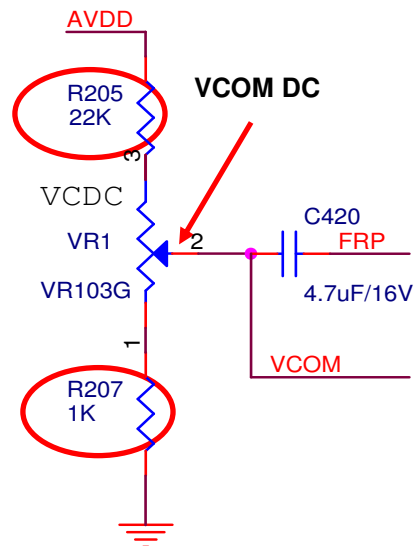

Note: The total of resistors for R205 , VR1 and R207 must be between 20K and 50K

b. VCOM Couple capacitor

The original panel structure is Cst on gate and the new model is Cst on common.

To avoid Horizontal Cross Talk, AUO suggest modify VCOM couple capacitor (C420) from 1uF to 4.7uF.

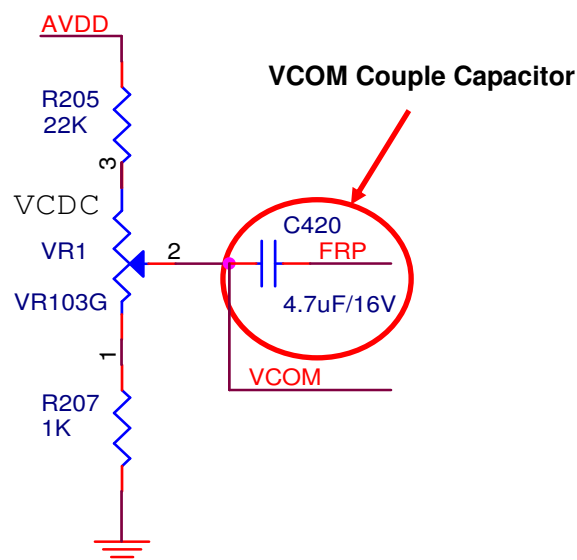

c. PWM RC Parameters

AUO suggests fine-tuning PWM RC parameters to get best display performance. If wave like noise phenomenon happened, please fine-tune RWM RC Parameters. By the way, please modify R208 from 30 ohm to 24 ohm to get 25 mA LED current. About the recommend RC Parameters, please refer the following figure.

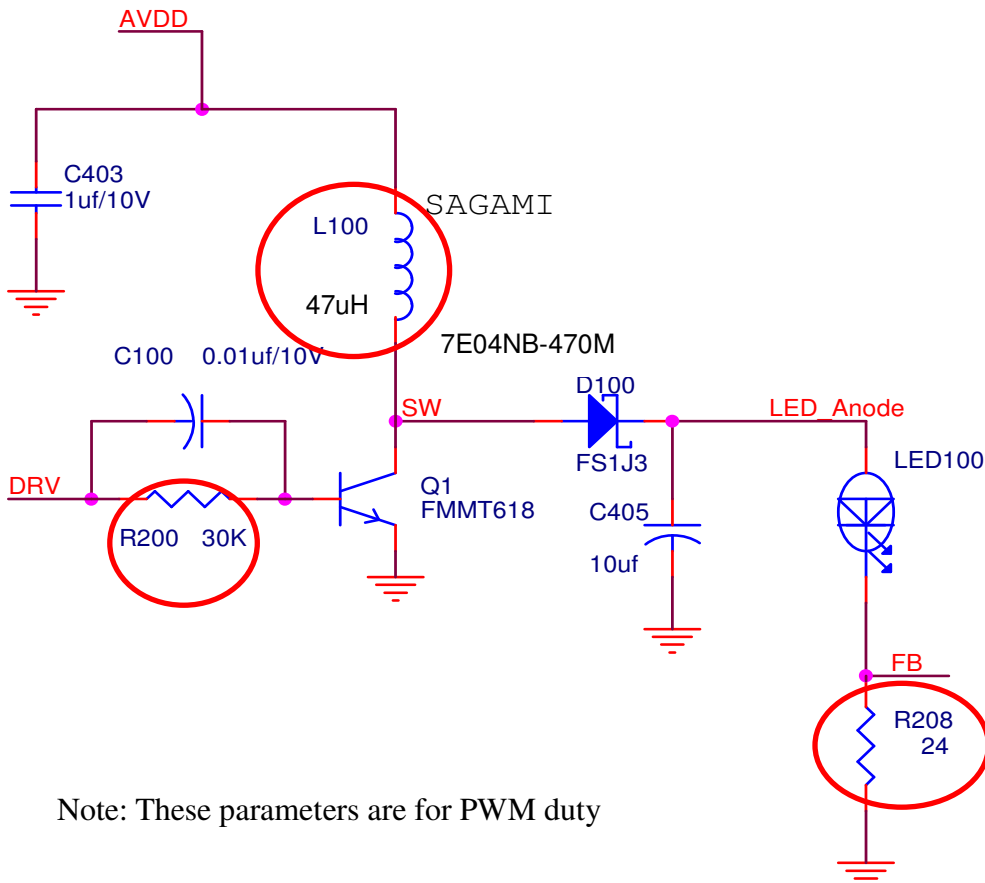

Note: These parameters are for PWM duty

d. ESD Protection

- a. AUO suggests always send serial commend to avoid shutdown phenomenon.
- b. AUO suggests connect iron shell to system GND to enhance ESD protection ability.